



Operating Manual

SkyFix Mk3 Decoder

REVISION DATE	DESCRIPTION	VERSION	PREPARED BY	CHECKED BY	APPROVED BY
16 Feb 2005	First Release	1.01	SRO	JEJ	AMJ
16 Feb 2005	After review	1.02	SRO	JEJ	AMJ
18 Feb 2005	Issued	1.03	SRO	JEJ	AMJ
23 Mar 2005	Inserted new information uplink channel on page 51	1.04	SRO	JEJ	AMJ



--	--	--	--	--	--



Information:

Fugro Demodulator	Fugro SkyFix Mk3 Decoder	
Serial Number	21_ _ _ _ _	
Contact Information	Fugro OPCO name:	
	Telephone contact	
	Email contact	
	Website contact	

Out of hours Contact (24hr):

Fugro Network Control Centre	
Network Centre:	Fugro Network Control Centre, Perth
Telephone Contact	+61 - 8 9321 0284
Fax Contact	+61 - 8 9321 0285
Email Contact	ncc@omnistar.com.au
Fugro Network Control Centre	
Network Centre:	Fugro Network Control Centre, Houston
Telephone Contact	+1 - 713 243 1342
Fax Contact	+1 - 713 266 0140
Email Contact	ncc@omnistar.com

1	SKYFIX MK3 DECODER SYSTEM DESCRIPTION	5
2	INSTALLATION	6
2.1	INSTALLATION	6
2.2	GPS ANTENNA LOCATION	7
2.3	CABLE INSTALLATION	7
2.4	POWER REQUIREMENTS	7
2.5	INTERFACING AT BACK PANEL	7
2.6	COM PORT CONFIGURATION	8
2.7	FRONT PANEL	9
3	INITIAL START-UP	11
3.1	TO SWITCH THE RECEIVER ON – OPERATIONAL MODE	11
3.2	TO SWITCH THE RECEIVER OFF	11
3.3	TO SWITCH THE RECEIVER ON – CONFIGURATION MODE	12
3.4	INITIALISATION CYCLE	12
4	RECEIVER OPERATION	13
4.1	REFERENCE STATION SELECTION	13
4.2	SATELLITE CHANNEL SELECTION	13
4.3	PORT 1, 2, 3, 4 BAUD RATE, PARITY SETTINGS	14
4.4	CHANGING THE BACKLIGHT SETTING OF THE TEXT DISPLAY	14
5	MANUAL SKYFIX MK3 DECODER -OPERATIONAL MODE	15
5.1	LIGHT INDICATORS (LED'S)	15
5.2	BUTTONS PAGE, TOGGLE, ENTER	15
5.3	MENU STRUCTURE IN OPERATIONAL MODE	15
5.4	MESSAGES	17
5.5	TROUBLE SHOOTING	18
6	USER CODE	19
7	CONFIGURATION MODE	20
7.1	TO SWITCH THE RECEIVER ON – CONFIGURATION MODE	20
7.2	MENU STRUCTURE IN CONFIGURATION MODE	20
7.3	PORT SETUP	30
7.4	CHANNEL CONFIGURATION	31
8	INTERNAL GPS RECEIVER	34
8.1	INTRODUCTION	34
8.2	GENERAL THEORY	34
8.3	DECODER TYPES	34
8.4	GPS CONFIGURATION	35
9	USING THE TOOLKIT	36
10	GLOSSERY	36
	APPENDICES	37
	APPENDIX A: SKYFIX MK3 DECODER SPECIFICATIONS	38
	APPENDIX B: GPS SETUP	39
	APPENDIX C: PIN LAYOUT POWER, OUTPUT PORTS AND ANTENNAE	43
	APPENDIX D: TROUBLE SHOOTING	45



APPENDIX E: INTERFACING Mk3 DECODER TO STARFIX.IOWIN	47
APPENDIX F: TOOLKIT.....	49
APPENDIX G: AVAILABLE UPLINK CHANNELS.....	51

Table of figures

Figure 1: Installation of SkyFix Mk3 Decoder.....	5
Figure 2: Back panel of SkyFix Mk3 Decoder.....	6
Figure 3 Back Panel of Mk3 Decoder	8
Figure 4: Com Port Extension Block for Port 1 + 3 or Port 1 + 4	8
Figure 5 Front Panel of Mk3 Decoder	9
Figure 6: Switch the Mk3 Decoder on – Operational Mode.....	11
Figure 7: Switch the Mk3 Decoder off	11
Figure 8: Switch the Mk3 Receiver on - Configuration Mode.	20
Figure 9: Internal Configuration of Mk3 with Gps.....	34
Figure 10 Port 1: NMEA Output	47
Figure 11 Port 2: RTCM Output	47
Figure 12 Port 3: Trimble DSM output	47
Figure 13 Port 4: Super Compressed	48
Figure 14: Inmarsat satellite Coverage Map	52
Figure 15: Spotbeam Satellite Coverage Map.....	53

1 SkyFix Mk3 Decoder System Description

This manual has been prepared to cover the introduction into field use of the SkyFix Mk3 Decoder unit. This receiver is based upon the single board decoder/demodulator. The manual covers installation, set-up, operation and basic trouble shooting for the various receiver configurations. Fugro's SkyFix Mk3 decoder is the decoder formerly known as 90938 decoder.

It's primary function is to decode the Starfix Differential GPS signals for output as super-compressed RTCM or uncompressed RTCM signals.

Variations of this unit incorporate a GPS receiver board. The GPS receiver options allow the SkyFix Mk3 unit to output direct injection position information.

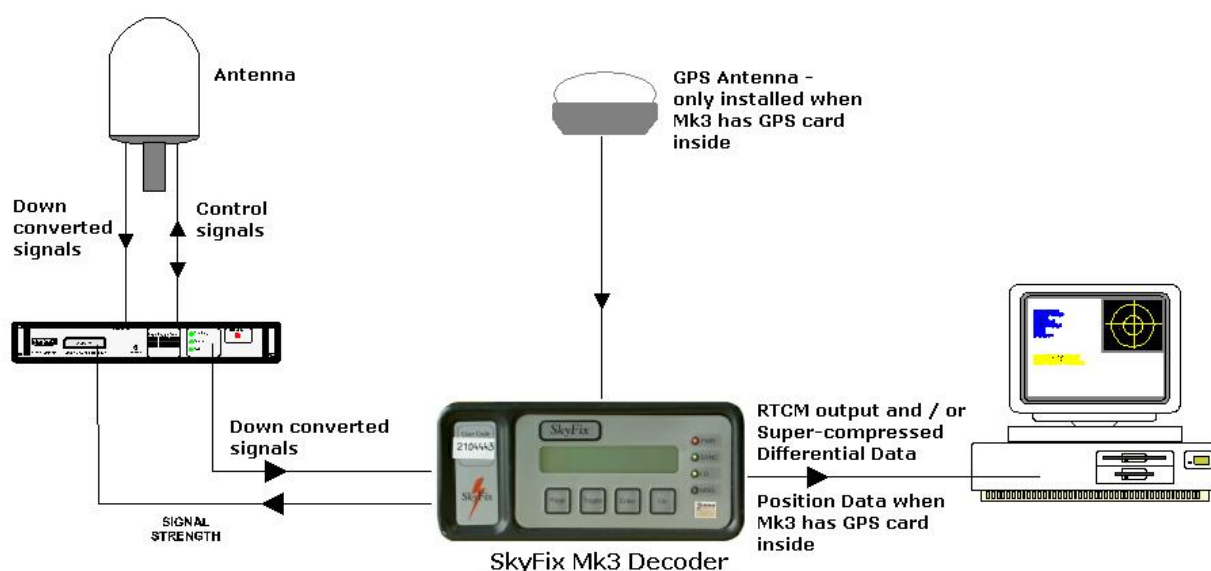

Figure 1: Installation of SkyFix Mk3 Decoder

The Mk3 consists of a decoder, internal demodulator software, CPU unit and optionally a Gps Receiver. The Mk3 demodulates the incoming signals. The output from the decoder board is so-called super-compressed differential information. The internal software, decodes this information into regular RTCM SC.-104 standard format to either an external GPS receiver, or an external software application or to one of the additional options internally.

The Mk3 unit has been designed to provide a light weight, low power consumption receiving unit capable of interfacing directly to a wide range of antennae, such as mini Dome, differential antennae.

2 Installation

2.1 Installation

1. Plug in the supplied cables and antenna lead. Ensure all cables are connected before applying power.
2. Mount the antenna in a suitable position so that there are no obstructions in any direction at the required satellite elevation angle.
3. Using the antenna control unit direct the satellite antenna to the correct elevation and azimuth angles for the required L band Inmarsat satellite. For more information on directing the antenna see the relevant manual.
4. Plug the RTCM data cable into PORT 1+3 and / or PORT 2+4.

WARNING

Ensure the SkyFix Mk3 unit is located away from direct heat or sunlight as this could cause the unit to overheat.

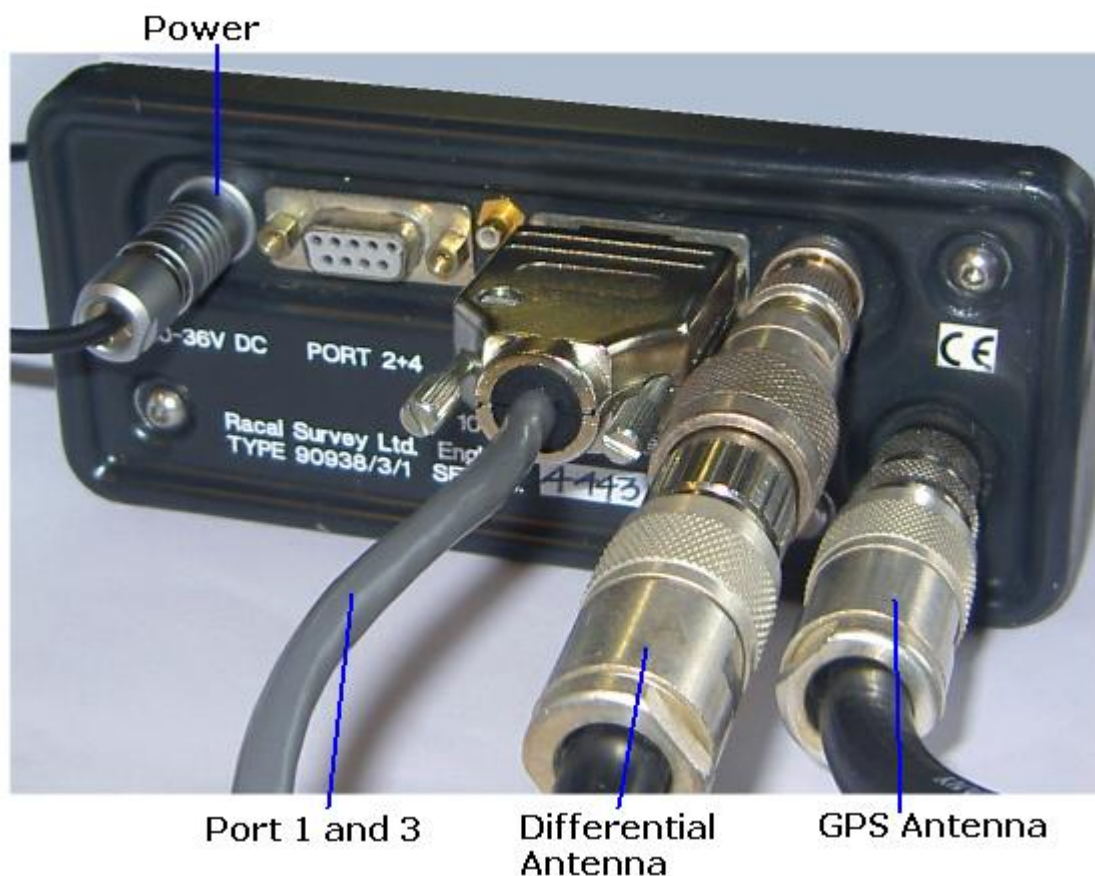

Figure 2: Back panel of SkyFix Mk3 Decoder

2.2 GPS Antenna location

This applies to Mk3 units with a GPS card only. For a proper installation of the GPS antenna, the following points should be considered:

- Do not install the GPS antenna nearby an INMARSAT installation.
- Avoid antenna installation too close to any other transmitting antennas.
- Make sure the antenna has an unobstructed view in every direction. If the antenna view is blocked (e.g. by a mast) between the satellite and the antenna, it is possible that the signal will be lost.
- Do **NOT** connect the antenna to the unit while it is still powered.

2.3 Cable installation

For a proper cable installation, the following points should be considered:

- Run the cable neatly from below deck to the antenna.
- Avoid the cable to be exposed in areas where it is likely to get damaged.
- Avoid the cable hanging to the connector without support.
- The biggest cable loss occurs with corroded connectors, make sure they are taped and protected against water ingress.

2.4 Power Requirements

The Mk3 unit requires the following power requirements:

- 10-36 VDC input voltage.
- power rating 7 watts

This is normally provided by AC/DC converter which is supplied when shipped. The characteristics of the converter are as follows:

AC/DC Converter

- Input :
 - 100 - 240v AC
 - 0.8 Amp
 - 47 - 63Hz
- Output:
 - +24 vDC
 - 30w power rating

2.5 Interfacing at back panel

The units back panel allows the connection of inputs and outputs to external equipment as well as the standard antennas and power.

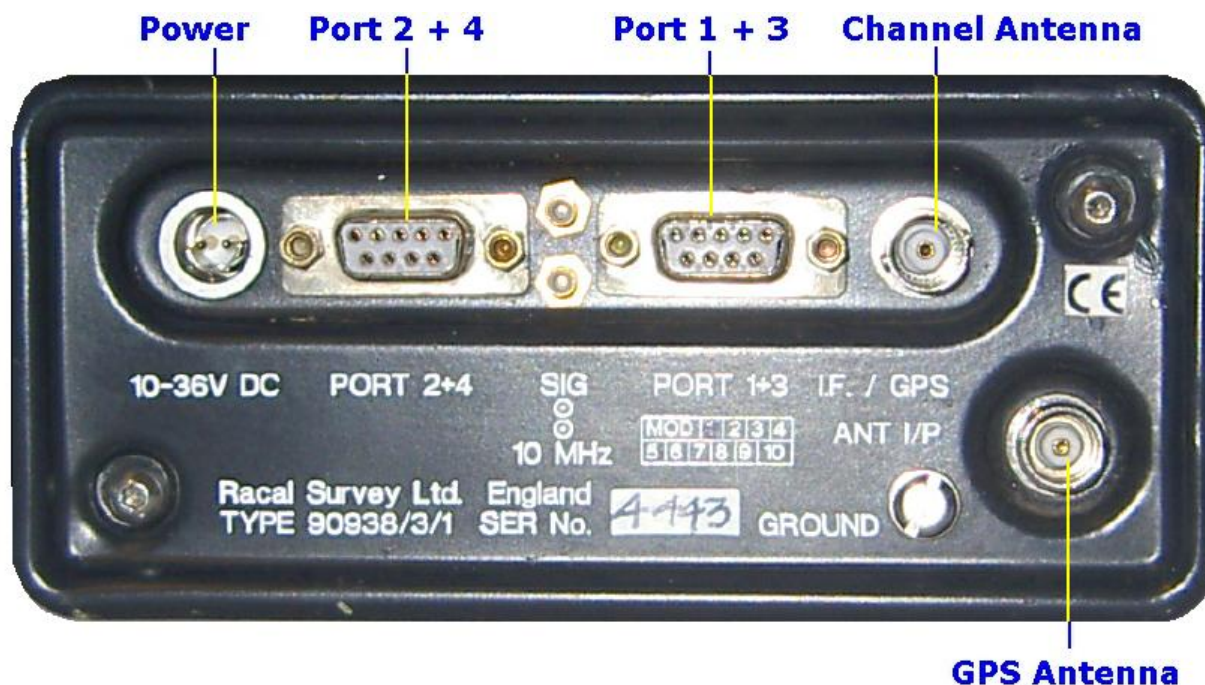

Figure 3 Back Panel of Mk3 Decoder

2.6 Com Port Configuration

The SkyFix Mk3 Decoder has 4 Com Ports available for I/O, and has been factory set-up as follows:

The rear panel of the receiver contains two DB9 pin connectors which support 2 serial ports each, an RF input for the demodulators input and an RF input for the GPS signal input (units with internal GPS cards).



Figure 4: Com Port Extension Block for Port 1 + 3 or Port 1 + 4

At the back of the unit there are two 9 pins connectors. These should be linked to a com-port extension block for splitting into separate Com ports.

Port Configuration for SkyFix Mk3 Decoder <u>without</u> GPS Card.		Starfix.IOWIN DII
PORT1	RTCM Output, max. 8 stations.	GPS Correction: RTCM In
PORT2	RTCM Output, max. 8 stations.	GPS Correction: RTCM In
PORT3	Available for Toolkit.	-
PORT4	Differential Information “RAW”.	GPS Correction: Super In

Port Configuration for SkyFix Mk3 Decoder <u>with</u> GPS Card.		Starfix.IOWIN DII
PORT1	NMEA output GGA, VTG, etc.	Position Input : NMEA
PORT2	RTCM Output, max 8 Station.	GPS Correction: RTCM In
PORT3	GPS output TSIP format, interfacing with GPS SETUP	GPS Receiver: Trimble DSM
PORT4	Differential Information “RAW”.	GPS Correction: Super In

- Ports (baud rate, etc.) can be configured with the receiver in Configuration Mode. Menu instructions can be found in section 7 Configuration Mode.
- Pin layouts can be found in Appendix C: Pin layout Power, Output Ports and Antennae

2.7 Front Panel

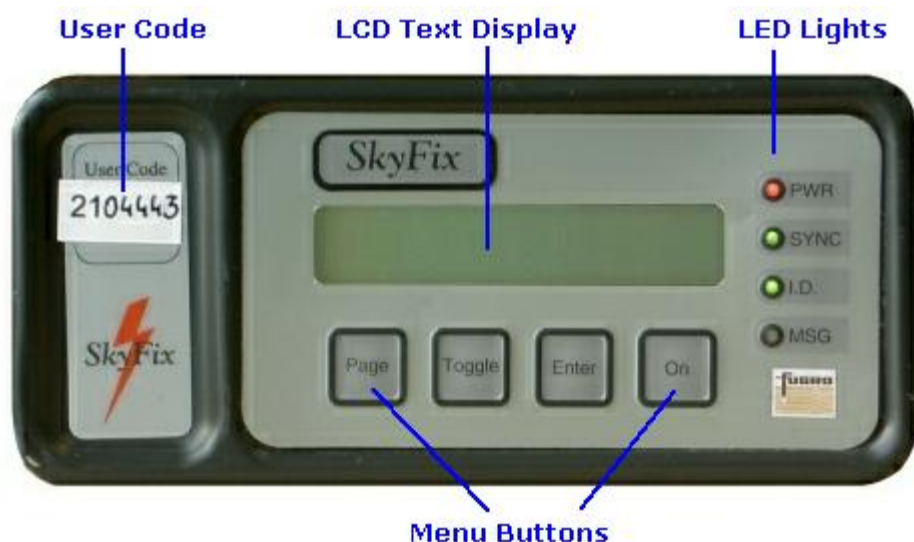

Figure 5 Front Panel of Mk3 Decoder

User Code	Your access code to the Starfix network.	See Section 6 User Code
LCD Text Display	Menu and Status Display.	
LED Lights	Lights showing status of Mk3 Decoder.	See Section 5.1 Light Indicators (LED's)



Menu Buttons	Buttons to navigate through menu and select settings.	See Section 5.2 Buttons Page, Toggle, Enter
--------------	---	---

3 Initial Start-up

The receiver allows for start-up in either one of two modes

- **Operational Mode:** to enter the normal operational mode, the user does not have to do anything: this is the default mode
- **Configuration Mode:** this mode is used for configuring the unit and to check the current system parameters. See 7 Configuration Mode.

3.1 To switch the receiver on – Operational Mode

To switch the receiver on, press the On button. After the receiver is switched on, then the Pwr light and the display light should both come on and a sharp beep can be heard. The beep indicates that the On command has been received.



Figure 6: Switch the Mk3 Decoder on – Operational Mode.

3.2 To switch the receiver off

To switch the receiver off, use the Page button until the menu item appears “Power Down ENTER” and press the ENTER button.



Figure 7: Switch the Mk3 Decoder off

3.3 To switch the receiver on – Configuration Mode

To enter the configuration mode, the user has to hold the Enter button immediately after the On button has been used. See Section 7 Configuration Mode.

3.4 Initialisation Cycle

After the receiver is switched on, a sharp beep can be heard. The beep indicates that the ON command has been received.

Operational Mode: without doing anything the receiver will continue in the Operational Mode.



The receiver will continue by performing a self test and by checking the User Code. The Code will appear in the screen after a couple of seconds. The green I.D light should come on. Read more about the codes in section 6 User Code.



The receiver will continue by searching for the differential antennae. It will use the last saved settings to determine what differential antenna system to check, in the picture example above the Channel was “EASAT”, this will vary depending on the user selection.

If successful the message “EASAT System Healthy” will appear (where EASAT is the Antenna system) followed by “EASAT ■■■■■■■■”. The number of blocks indicate the signal strength with a maximum of seven blocks. The Sync light should be on as well.

If no connection is found, then the message NO SIG will appear. You will have to correct this, so that the Mk3 Decoder can operate, see the section on 5.5 Trouble shooting.

The unit is now operational.

4 Receiver Operation

The following section intends to describe the most common actions with the SkyFix Mk3 Decoder. It is a brief guidance through the menu. For details on how to operate the menu see Section 5.3 Menu Structure in Operational Mode.

4.1 Reference Station Selection

The user can select Reference Stations from a list. The list is automatically transmitted via the (Satellite) Differential Antenna link. When powering up the SkyFix Mk3 Decoder in a new area, or after changing Channel link, it may take up to ten minutes for a new list to be downloaded.

The Reference Station(s) closest to your position should normally be selected.

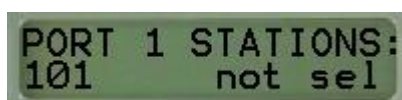

The list of Reference Stations can be seen when the receiver is in Operational Mode. Press Page until the menu “Port 1 Stations” or “Port 2 Stations” is seen.

- Press “Toggle to go through the list of Reference Stations.
- Each of the stations can be switched on or off, by pressing Enter, which will change the text from “not sel” to “selected” and vice versa.

	Mk3 with GPS	MK3 without GPS
PORT 1	Select maximum 1 station, which will be used to correct the GPS Position.	Select maximum 8 stations, which will be output via Port 1 at the back panel in RTCM format.
PORT 2	Select maximum 8 stations, which will be output via Port 2 at the back panel in RTCM format.	

If user does not have access to a reference station the display will show 'not avble'. The users access to the reference stations is controlled by the Fugro Network Control Centre.

The same menu is also available with the Mk3 Decoder in Configuration Mode: Menu: “1.Decoder → PORT 1 SETUP → PORT 1 STATIONS”.

4.2 Satellite Channel Selection

In areas of overlapping footprints, the user may require to change to receiving signals from a different satellite. To select a Satellite Channel, one needs to have the Mk3 Decoder in Operational Mode.

Select the menu DATA CHANNEL by pressing the Page button.



- Press “Toggle to go through the list of Reference Stations.
- Press Enter and Page to select the Station.

After selecting a new Channel, the list of Stations is empty will be downloaded in the next five minutes.

The signal strength of the newly selected Channel can be viewed in Operational Mode in the default view. Press Page until the following diagram is seen.



The list of Channels is configurable with the Receiver in Configuration Mode, see Menu [“2. Demodulator → Configuration”](#) or with the Toolkit, see 9 Using the Toolkit.

4.3 Port 1, 2, 3, 4 Baud rate, parity settings

The baud rates, parity settings of the output ports can be set with the Receiver in Configuration Mode, see section 7 Configuration Mode. Follow the Menu [“1.Decoder → PORT 1 SETUP → PORT 1 o/p”](#)

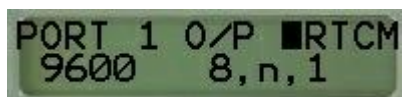

4.4 Changing the Backlight setting of the Text Display

This menu is accessible from the Power Control Menu in Operational Mode or Configuration Mode. Press Page until the Power Control menu is up.

Press 'Toggle' to display the backlight option.



Press 'Enter' to cycle through the following settings:

- psm Power saving mode - to save power, the backlight is switched off automatically if a key is not pressed for 2 minutes. The backlight is switched on again when a key is next pressed by the user.
- off Backlight is permanently off.
- on Backlight is permanently on.

5 Manual SkyFix Mk3 Decoder -Operational Mode

5.1 Light Indicators (LED's)

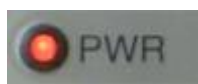

PWR indicates that power is being supplied to the internal boards

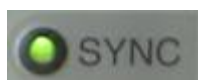

The SYNC LED ON indicates an allowable/enabled satellite channel has been selected.

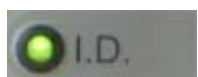

The ID Received LED indicates whether the subscription for this User Code is valid on the current date. On indicating a valid subscription. Off no valid subscription. Use the menu item Subscription to verify valid dates: see section 5.3 Menu Structure in Operational Mode.



The Message Update LED is redundant.

5.2 Buttons Page, Toggle, Enter

The functionality of the buttons varies, but the general function of the buttons is :



Next Menu item. Use page to step through the menu. Use Enter to step into a menu item.



Change setting.

















Go into menu item or
Accept setting.

5.3 Menu Structure in Operational Mode

In Operational Mode the following Menu is available.

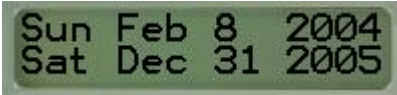

	<p>Receiver is in Operational Mode.</p> <p>The second line shows the Receiver Status and Health Messages, see Section 5.4 Messages.</p> <p>Toggle scrolls through any previous receiver status messages in the status. In 'Enter' deletes a message</p>
---	---





		from the status.
		To switch the Mk3 Decoder off, press Enter. To continue, press Page.
		Press 'Toggle' to display the backlight option.
		
		Press 'Enter' to cycle through the following settings: psm Power saving mode - to save power, the backlight is switched off automatically if a key is not pressed for 2 minutes. The backlight is switched on again when a key is next pressed by the user. off Backlight is permanently off. on Backlight is permanently on.
		Displayed is the current Channel for receiving the Differential Information. Use the Toggle button to change the Channel.
		Use the Enter button to select a Channel. After you have selected a different Channel, the list of Stations will be empty until a new list of Stations is received.
		Use the Toggle button to step through the list of Stations. A maximum of 8 Stations can be selected for Port 1. In the situation of an internal GPS card, Port 1 is connected to the GPS Receiver. Then only 1 Station should be selected, as this is the maximum that the GPS can handle. After changing of Channel or when powered up in a new area for the first time, it may take several minutes for the Reference Stations list to become available.
		Use the Enter button to select / not select (not sel) a Station.
		Use the Toggle button to step through the list of Stations.

		<p>Remember that for Port 2 a maximum of 8 Stations can be selected.</p> <p>After changing of Channel or when powered up in a new area for the first time, it may take several minutes for the Reference Stations list to become available.</p>
		Use the Enter button to select / not select (not sel) a Station.
		<p>Lists the subscription periods – wait 2 seconds for dates to appear.</p>  <p>No Toggle options. Press Page to continue.</p>
		<p>Lists the basic settings:</p> <p>RTCM means that output of RTCM is on. RAW means that the compressed signal is outputted on. LINK Status of Differential Link. SUB Subscription Status.</p>

5.4 Messages

Below follows a list of possible messages

	<p>This message means that the Mk3 is in Operational Mode.</p> <p>“EASAT” is the name of the differential connection. The  indicates the signal strength with a maximum of 7 blocks.</p> <p>Toggle scrolls through any previous receiver status messages in the status log. 'Enter' deletes a message from the status.</p>
---	---

	<p>The “System Health” message appears on start-up or when changing differential connections through the menu. It means that the receiver has found the channel and the differential connection is healthy.</p>
<p>System Healthy</p>	<p>Only displayed for a few seconds after power up, if no errors have been found</p>
<p>Demod.fail Xxx</p>	<p>Demodulator failed its self test. Xxx = error code</p>
<p>NVRAM error(s)</p>	<p>Error detected in memory backup of stored configuration parameters.</p>
<p>Access Changed</p>	<p>The Fugro Network Control Centre has changed the allowed access to reference stations.</p>
<p>New Station List</p>	<p>The list of reference stations displayed under the 'Stations' menu has changed.</p>
<p>No Signal</p>	<p>The receiver has lost the signal.</p>
	<p>This happens if the connection to satellite or Differential Antenna is not available. It could be that the Antenna is not plugged in.</p>
<p></p>	<p>The Decoder will not work. Verify why the signals are not received by checking wiring.</p>
	<p>This message appears on start-up. It indicates that the receiver is checking the User Code. It should be followed within a couple of seconds with the User code.</p>
	<p>This message appears on start-up or when in Configuration Mode-> Decoder Menu.</p>
<p></p>	<p>Read more about the User Code in section 6.</p>
	<p>This typically happens after start-up in a new area or after Channel has been changed. The list of Reference Stations available has not yet been received. This may take several minutes.</p>
<p></p>	<p>If after ten minutes still no list is available, then try switching the Mk3 Decoder off and on.</p>
<p></p>	<p>Alternatively, if a specific Station is named (e.g. “201 not avble”), then this message indicates that the control centre has disabled the use of this station for your user code.</p>

5.5 Trouble shooting

For further assistance read Appendix D: Trouble shooting

6 User Code

Every unit has a different User Code programmed into the tamperproof processor on the Data Decoder board.

The Fugro Network Control Centre addresses individual units by their User Code to switch access on/off. The User Code on the display should be the same as the User Code label on the Front Panel. Depot service engineers must ensure that the tamperproof processor IC remains with its corresponding case when attempting to change boards.

The User code of the SkyFix Mk3 units is a seven digit number, always starting with 21. So the number is 21xxxxxx.

7 Configuration Mode

The Configuration Mode of receiver operation allows access to receiver functions which would normally be pre-configured prior to delivery. For example, the serial port data rates and channel configurations are set up in the Configuration mode.

7.1 To switch the receiver on – Configuration Mode



Figure 8: Switch the Mk3 Receiver on - Configuration Mode.

Press the On Button and wait for the Pwr light and the beep tone. Hold the Enter button after the beep and until the Pwr, Sync and ID lights are on.

Release the Enter button when the message “User Code: xxxxx” appears in the screen. The SkyFix Mk3 receiver is now in Operational Mode.

Note: make sure you release the Enter button in time.

7.2 Menu Structure in Configuration Mode

Five Main menu items are available

1. [Decoder](#) Enables the data output ports to be set up.
2. [Demodulator](#) Enables the demodulator parameters to be viewed/selected and the pre-stored channel names and set up parameters to be configured.
3. [Alarms](#) Enables the audible alarm triggers to be set and messages to be viewed
4. [System Checks](#) Shows health of the system and runs system tests, such as tests for the lights, text display, etc.
5. [Power Control](#) Controls the display backlight and allows the unit to be powered down (same as the Operational Mode).

Within each of the main menus there are several sub menus, the full menu structure is as follows :







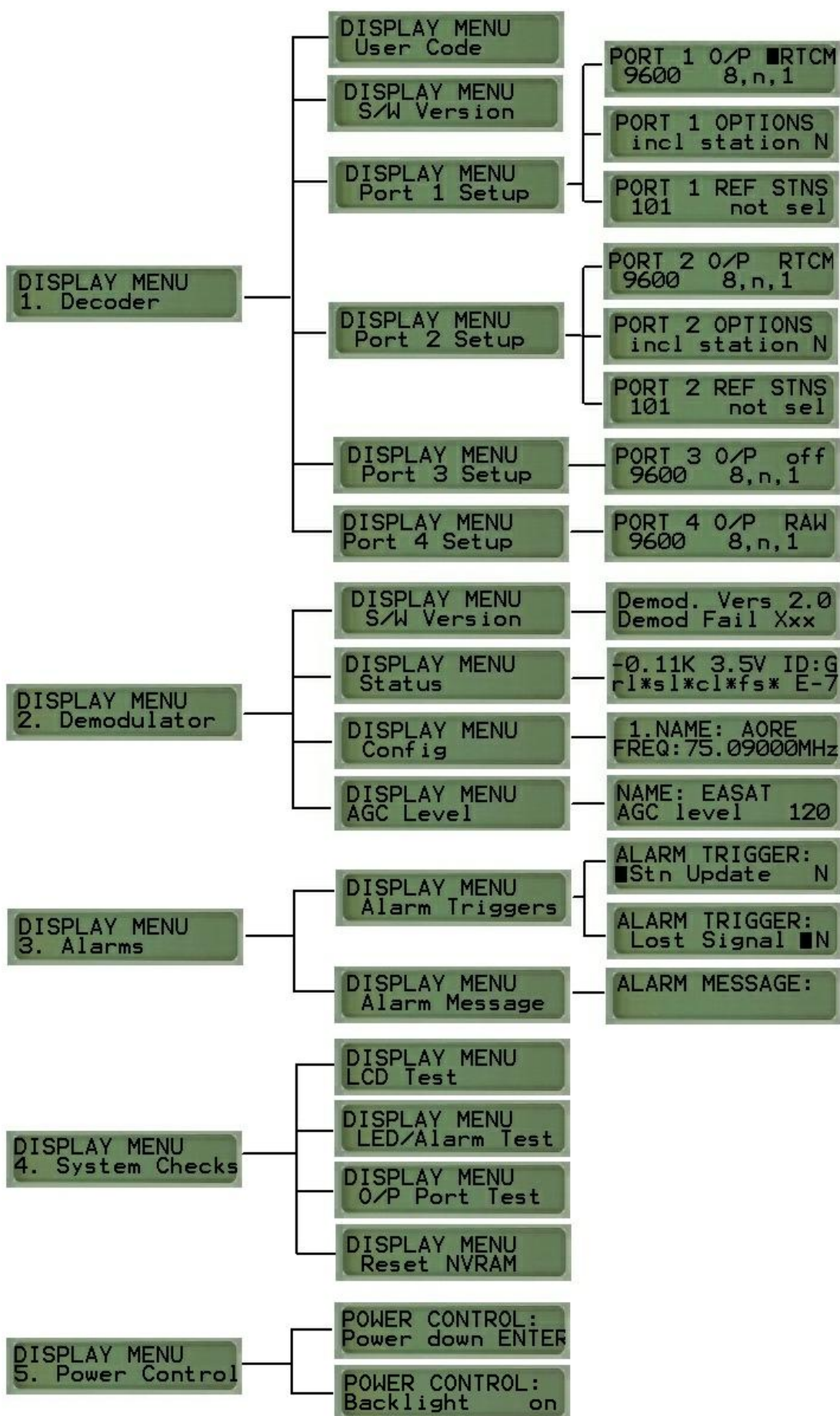









There are two types of menu page, information and configuration pages. The information pages are for display only, while the configuration pages allows alteration of the system settings as indicated by a flashing cursor. To select the different menus use the page key to select which menu required and the enter key to accept selection.



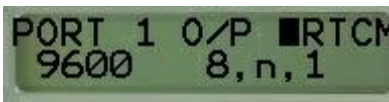

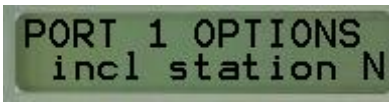

On editable configuration pages, a flashing cursor indicates that a parameter can be changed. The 'Toggle' key changes a parameter to the next available value. By pressing 'Enter' the selected value will be accepted and the cursor moved to the next parameter field.











Details Menu Structure:

	<p>The decoder is the hard ware that takes care of decoding the incoming data via the Differential Antenna.</p>
	<div style="display: flex; align-items: center;">  <p>When Enter is pressed, then the User Code is displayed.</p> </div> <div style="margin-top: 10px;">  </div> <p>Press Page to exit this menu. Read more on User Code in section 6 User Code.</p> <p>Toggle Options: none</p> <p>Do not press Enter or Toggle here again, as the User Code cannot be changed through this menu. (if pressed, then the Mk3 decoder continues in Operational Mode).</p>
	<div style="display: flex; align-items: center;">  <p>Displays the S/W Version of the versions for the internal processing.</p> </div> <div style="margin-top: 10px;">  </div> <p>Should be version “2.11 1.40” or higher</p> <p>Toggle Options: none.</p> <p>Press Page to exit this menu.</p> <p>There are two processors on the Data Decoder board.</p> <p>The right hand version number displayed is for the tamperproof processor software which performs the decoding. The left hand version number is for the software in the second processor, which performs the output formatting and display control</p>















		<p>Port 1 of the SkyFix Mk3 Decoder is configurable for RTCM output, either to Port 1 on the back panel, or to an internal GPS Card.</p> <p>Port 1:</p> <ul style="list-style-type: none"> - Mk3 with GPS: Select maximum one Reference Station for use with GPS. Baud rate and other settings for Port 1 are configured through the GPS card. - MK3 without GPS: Select maximum of 8 Reference Stations for output through Port 1. <p>Enter the Setup menu by pressing Enter.</p>
		<p>These settings for Port 1 are only applicable to SkyFix Mk3 Decoders without GPS Card.</p> <p>Decoders with GPS Card use Port settings from the GPS configuration, see 8 Internal GPS receiver.</p> <p>The minimum baud rate with 8 Stations selected:</p> <ul style="list-style-type: none"> • 4800 for 1200 user data rate • 9600 for 2400 user data rate <p>For instructions on how to operate this menu see 7.3 Port Setup.</p>
		<p>Press Page to get to next menu item: "PORT 1 OPTIONS".</p>
		<p>This option regulates whether text messages related to individual reference stations are included.</p> <p>Press Enter to change between N and Y (No and Yes).</p> <p>If Port 1 O/P is set to 'off', the Port 1 options page will display '>PORT IS NOT SEL' and the Toggle and Enter keys will be inoperative.</p>
		<p>Press Page to get to next menu item: "PORT 1 REF STNS".</p>
		<p>Use the Toggle button to step through the list of Reference Stations.</p> <p>A maximum of 8 Stations can be selected for Port 1.</p>

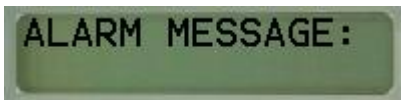





			<p>If Port 1 is connected to a GPS Receiver, then only 1 Station should be selected, as this is the maximum that the GPS can handle.</p> <p>After changing of Channel or when powered up in a new area for the first time, it may take several minutes for the Reference Stations list to become available.</p>
			 <p>Use the Enter button to selected / not selected (not sel) a Station.</p>
			 <p>Press Page to leave the sub-menu for Port 1 Setup.</p>
			 <p>Port 2 is configurable for RTCM output.</p> <p>A maximum of 8 stations can be selected.</p> <p>Format options are RTCM or off.</p> <p>Same menu instructions as for Port 1 Setup.</p>
			<p>Format options are RTCM or off.</p> <p>The minimum baud rate with 8 Stations selected:</p> <ul style="list-style-type: none"> • 4800 for 1200 user data rate • 9600 for 2400 user data rate <p>For instructions on how to operate this menu see 7.3 Port Setup.</p>
			<p>See Port 1.</p>
			<p>A maximum of 8 stations can be selected.</p> <p>This menu is also available in Operational Mode.</p> <p>For instructions see Port 1.</p>

		<p>Port 3:</p> <ul style="list-style-type: none"> - Mk3 with GPS GPS Position Output. Toolkit cannot be used. Note: it is possible to use the toolkit if unit is opened and jumper settings changed. This should be done by a trained engineer only. - MK3 without GPS: Port 3 is available for operation with the Toolkit, see 9 Using the Toolkit. <p>Enter the Setup menu by pressing Enter.</p>
		<p>These settings for Port 3 are only applicable to SkyFix Mk3 Decoders without GPS Card.</p> <p>Decoders with GPS Card use Port settings from the GPS configuration.</p> <p>Options are REM or off. Press Enter to select the option.</p> <p>REM means available for Toolkit see 9 Using the Toolkit. You cannot do anything else with the unit until setting is set to “off” again. REM sets Port 3 input and output into the OEM Remote Interface Mode, to allow remote control of the receiver from an external device. REM is not used in normal operation.</p> <p>For instructions on how to operate this menu see 7.3 Port Setup.</p>
		<p>Port 4 is reserved for forwarding the decoded Differential information as it is, also called Super-compressed.</p>
		<p>Options are RAW or off. RAW means that the information received via the Differential Antenna link are output as they are (“Super-compressed”).</p> <p>For instructions on how to operate this menu see 7.3 Port Setup.</p>
		<p>The Demodulator is the software that takes care of demodulating the incoming signal.</p>

<p>DISPLAY MENU S/W Version</p>		<p>Displays the S/W Version of the Demodulator. Should be version 2.0 or higher.</p> <p>Demod. Vers 2.0</p> <p>Toggle options: none.</p> <p>Use Page to exit menu.</p> <p>Note: If the demodulator fails its power up self test, the bottom line of the display will show 'Demod Fail Xxx' where Xxx is a 3 digit failure code.</p> <p>Demod. Vers 2.0 Demod Fail Xxx</p>																		
<p>DISPLAY MENU Status</p>		<p>Displays the current status of the demodulator section of receiver. If you encounter any problems with the receiver, this page, together with the front panel LEDs, provides a useful aid to troubleshooting.</p> <p>-0.11K 3.5V ID:G rl*sl*cl*fs* E-7</p> <p>Toggle Options: none Press Page to exit.</p> <p>For correct receiver operation, all the diamonds should be solid. This indicates that the receiver is fully locked on to the signal.</p> <table border="1" data-bbox="783 1435 1422 2033"> <tr> <td>Frequency Offset</td> <td>Should be in the range +3.50 kHz.</td> </tr> <tr> <td>Signal Strength</td> <td>< 1 V poor signal levels > 2 V good signal levels</td> </tr> <tr> <td>Service ID</td> <td>'G' will be shown.</td> </tr> <tr> <td>BER</td> <td>Bit Error: E-0 Bad, E-7 good. Rate is typically E-5 to E-7</td> </tr> <tr> <td>rl</td> <td>Reference lock. Indicates that internal synthesiser is locked. This is independent of the received satellite signal.</td> </tr> <tr> <td>sl</td> <td>Symbol lock acquired.</td> </tr> <tr> <td>cl</td> <td>Carrier lock acquired.</td> </tr> <tr> <td>fs</td> <td>Frame synchronisation acquired.</td> </tr> <tr> <td>◆</td> <td>OK</td> </tr> </table>	Frequency Offset	Should be in the range +3.50 kHz.	Signal Strength	< 1 V poor signal levels > 2 V good signal levels	Service ID	'G' will be shown.	BER	Bit Error: E-0 Bad, E-7 good. Rate is typically E-5 to E-7	rl	Reference lock. Indicates that internal synthesiser is locked. This is independent of the received satellite signal.	sl	Symbol lock acquired.	cl	Carrier lock acquired.	fs	Frame synchronisation acquired.	◆	OK
Frequency Offset	Should be in the range +3.50 kHz.																			
Signal Strength	< 1 V poor signal levels > 2 V good signal levels																			
Service ID	'G' will be shown.																			
BER	Bit Error: E-0 Bad, E-7 good. Rate is typically E-5 to E-7																			
rl	Reference lock. Indicates that internal synthesiser is locked. This is independent of the received satellite signal.																			
sl	Symbol lock acquired.																			
cl	Carrier lock acquired.																			
fs	Frame synchronisation acquired.																			
◆	OK																			



			◇	error				
				<p>Gives access to menu for Channel configuration.</p> <p>Read for further instructions section 7.4 Channel Configuration</p> <p>Channel 16 is the only user-configurable channel.</p> 				
				<p>Displays AGC level:</p>  <p>Toggle Options: none. Press Page to exit.</p> <p>The AGC Level page shows a 3 digit number representing the AGC (Automatic Gain Control) setting which the receiver automatically adjusts to compensate for differing input signal levels. The limits are 0 to 255, with 255 representing maximum gain when the input signal level is at a minimum.</p>				
								
				<p>The alarm triggers produce an audible alarm when certain conditions occur. The audible alarm occurs besides the regular messages.</p> <p>The alarms are particularly useful when the receiver is being carried in a man pack where the display cannot be easily observed.</p>				
				<p>Use Toggle to toggle between Stn Update and Lost Signal when cursor (black block) is at the start.</p> <table border="0"> <tr> <td style="vertical-align: top;">Stn updated Y/N</td> <td>An alarm is raised if there is a change in the list of reference stations downloaded to the receiver. For example, this may occur when a new reference station is made available by Fugro.</td> </tr> <tr> <td style="vertical-align: top;">Lost signal Y/N</td> <td>An alarm is raised if the received signal is lost.</td> </tr> </table>	Stn updated Y/N	An alarm is raised if there is a change in the list of reference stations downloaded to the receiver. For example, this may occur when a new reference station is made available by Fugro.	Lost signal Y/N	An alarm is raised if the received signal is lost.
Stn updated Y/N	An alarm is raised if there is a change in the list of reference stations downloaded to the receiver. For example, this may occur when a new reference station is made available by Fugro.							
Lost signal Y/N	An alarm is raised if the received signal is lost.							

			Use Enter to move cursor from left to right and from right to left.
			Use Toggle to toggle between Y and N when cursor (black block) is at the end.
			Press Page to leave menu Alarm Triggers.
			This menu lists the messages that will be shown. If the audible alarm sounds, the type of alarm which triggered the alarm is shown on the Alarm Message page.
			Toggle Options: Use Toggle to move between error messages. Pressing Enter will remove the messages. Use Page to leave menu item. Message: <ul style="list-style-type: none"> • Ref. List Updated • Access change • No Messages
			Use the options on the System Checks menu to run tests on the receiver.
			Press Enter to run a test to check whether the LCD (Text Window) is working properly. One should see a series of black blocks appearing: 
			Cycles through a test pattern whereby the lights and audible alarms are engaged.
			Press 'Enter' to run the O/P Port test. This test sends a test message to each O/P port at the baud rate and format shown on the corresponding Port Set Up page. Connect a terminal to each port before running the test and check that the test message is received. The receiver performs an automatic loop back test from output port to input port on each serial port and displays the results of these tests as a 'Pass' or 'Fail'.





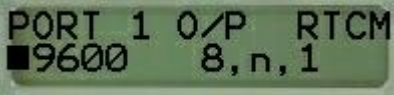
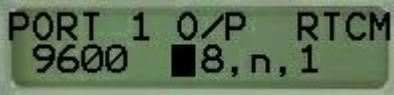

		<p>Pressing Enter will reset the all settings to the default.</p> <p>If the receiver has a fault and does not recover by powering off and on, it is possible that the battery backed up Non Volatile Random Access Memory (NVRAM) has been corrupted. This memory stores all the user entered set up data (e.g. channel configurations, port settings etc.) and can be reset to the default settings if a fault is suspected.</p> <p>Resetting the NVRAM will clear all channel frequency settings and other data. Do not attempt this unless you know how to reconfigure these settings.</p> <p>Note: The memory is reset to the default settings only after the receiver is powered off and on.</p>
		<p>Press Enter to power down.</p>
		<p>Press Toggle to go the Backlight menu</p>
		<p>To power down the receiver simply press 'Enter'. The receiver can be switched on again by pressing the 'On' key.</p>
		<p>To change the Backlight setting, press 'Toggle' to display the backlight option</p> <p>Press 'Enter' to cycle through the following settings:</p> <ul style="list-style-type: none"> psm Power saving mode - to save power, the backlight is switched off automatically if a key is not pressed for 2 minutes. The backlight is switched on again when a key is next pressed by the user. off Backlight is permanently off. on Backlight is permanently on. <p>Menu also available in Operational Mode.</p>













7.3 Port Setup



		<p>Press Enter to cycle through RTCM, 9600 and 8,n,1.</p>
---	---	---

		 	<p>Enter accepts the currently visible option.</p>
			<p>The Options can be changed using the Toggle Button.</p> <ul style="list-style-type: none"> - RTCM or off. - 300, 600, 2400, 4800, 9600, 19200, 38400 baud rate. - 8,n,1, 8,n,2, 8,e,1, 8,e,2, 8,o,1, 8,o,2 parity. <p>The minimum baud rate with 8 Stations selected:</p> <ul style="list-style-type: none"> • 4800 for 1200 user data rate • 9600 for 2400 user data rate
			<p>Press Page to get to next menu item.</p>

7.4 Channel Configuration

		<p>The Configuration menu gives access to menu for Channel configuration.</p> <p>Changing the settings here will only be kept if they are done for Channel 16. Channel 16 is the only user-configurable channel.</p>
		<p>Next Channel.</p>
		<p>Step into the settings menu for this Channel.</p>
		<p>You are now in the settings menu for this Channel.</p>
		<p>Step through the settings .</p> 

			 
			<p>Press Enter to change the setting.</p> <p>Note: the current settings disappear from the screen, but are not lost yet. If you press Page or Toggle, you go out of this setting and the old setting returns.</p> <p>Changes are saved after the change was made AND the Enter button was pressed.</p>
			<p>Pressing Enter allows you to change the name.</p>  <p>Use Toggle to cycle through the characters, A, B, C, etc.</p> <p>Use Enter to go to the next position.</p> <p>Press Enter twice to accept a name and continue.</p>
			<p>Pressing Enter allows you to change the frequency.</p>  <p>Use Toggle to cycle through the numbers, 1, 2, 3, etc.</p> <p>Use Enter to go to the next position.</p> <p>Valid frequencies are in the range 63.00000 to 83.50000mhz, however the last three digits must be in multiples of 1.25kHz e.g. 63.00125, 63.00250, 63.00375 etc.</p> <p>Press Enter twice to accept the frequency and continue.</p>
			<p>Pressing Enter allows you to change the data rate.</p> 

				<p>User Toggle to select: 600, 1200, 2400 or 4800.</p> <p>Use Enter to accept.</p>
				<p>Pressing Enter allows you to change the IF level indicating the level of the signal.</p>  <p>Use Toggle to select high or low.</p> <p>Use Enter to accept.</p>

8 Internal GPS receiver

8.1 Introduction

The standard SkyFixMk3 Decoder will output differential corrections and status information only, not positional information. However with an internal GPS card the SkyFix Mk3 becomes a fully integrated positioning tool without the requirement for any external GPS receiver.

8.2 General theory

As shown in Figure 9: Internal Configuration of Mk3 with Gps, the demodulator/decoder boards port 1 is connected internally to the input on COM A on the GPS Receiver to provide RTCM corrections. The GPS card is configured to accept only data from any single station, so the user must select only one station to be output from port 1 on the demodulator/decoder (see Section “[Port 1 Configuration](#)”)

The output from the GPS’s COM A, the NMEA GGA and VTG positional output string, is connected to the back panel on port 1.

The GPS’s COM B, connected to port 3 on the Mk3 back panel, is used to configure the GPS card using TSIP protocol or the GPS SETUP program as described in Appendix B: GPS Setup.

The demodulator/decoder board’s port 2+4, connected to port 2+4 on the back panel, allows the output of RTCM data and the RAW differential information.

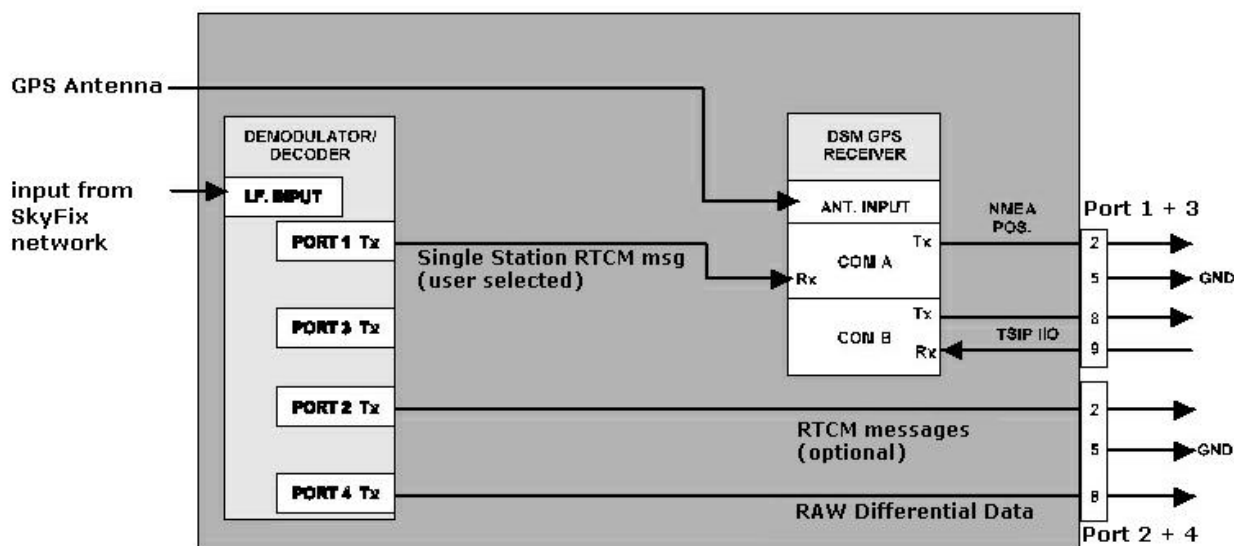

Figure 9: Internal Configuration of Mk3 with Gps

8.3 Decoder Types

The following types of SkyFix Mk3 Decoder types exist, amongst others:

- SkyFix Mk3 Decoder.
- SkyFix Mk3 Decoder with Trimble BD112 GPS card.
- SkyFix Mk3 Decoder with Trimble SK8 GPS card.
- SkyFix Mk3 Decoder with Trimble DSM GPS card.

If a GPS card is present then Differential Data (RTCM and Super-compressed format) and Position output is available.

Without a GPS card no positions are available, only the Differential Data output is available. The user requires an external GPS receiver to obtain Position information.

8.4 GPS Configuration

As the GPS card has no direct user interface, configuration of the unit is achieved by Software running on an external computer program, called GPSSETUP. The Software resets the DSM card back to factory defaults and then alters the relevant settings in accordance with Fugro's recommendations. If alternative settings are required, other than the Fugro's defaults, then a DSM.INI file can be created. DSM.INI will contain a list of the settings which have been changed in TSIP Format.

Read Appendix B: GPS Setup for instructions on GPS SETUP.

9 Using the Toolkit

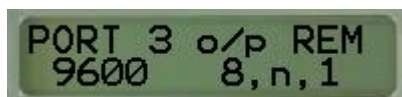

The Toolkit is a program which allows extended configuration of the Mk3 Decoder. The program communicates with the Mk3 Decoder through Port 3 of the Mk3 Decoder, when the format for Port 3 is set to “REM”.



Make sure you press Enter after selecting the option REM.

Read Appendix F: Toolkit for more information.

10 Glossery

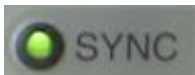
Button		Four buttons on the front panel. See section 5.2 Buttons Page, Toggle, Enter.
Channel		The Differential GPS information is broadcast via Channels. It indicates a connection for the Differential Signal, i.e. Satellite Type, frequency, etc.
Differential Link		Same as Channel.
LCD		Text Display
LED Light		Four lights on the front panel. See section 5.1 Light Indicators (LED's).
Station		Short for Reference Station. Indicates a station where the Differential GPS data originates from. The operator has to choose which station to use, usually the closest.
Sub		Short for Subscription. Indicates subscription to the Starfix network for Differential GPS information.
User Code		See section 6 User Code.



Appendices

- Appendix A: SkyFix Mk3 Decoder specifications
- Appendix B: GPS Setup
- Appendix C: Pin layout Power, Output Ports and Antennae
- Appendix D: Trouble shooting
- Appendix E: Interfacing Mk3 Decoder to Starfix.IOWIN
- Appendix F: Toolkit
- Appendix G: Available Uplink Channels

Appendix A: SkyFix Mk3 Decoder specifications

Physical Characteristics

Receiver Size:	260mm D x 150mm W x 75mm H
Weight:	1.5 kg (incl. Trimble DSM card and 386/486 processor card)
Display:	2 line x 16 character back lit LCD display
Operating temp:	0 to -50 deg C

Technical Specifications

SkyFix Receiver	<ul style="list-style-type: none">- 2 independent RTCM SC-104 ver 2.0 RS232 outputs (one internally connected for DSM option)- Acquisition time from switch on typically <20 seconds- Reacquisition time typically < 10 seconds
I.F. Interface	<ul style="list-style-type: none">- 63 to 83.5 MHz (for connection to tapped I.F. output from Inmarsat terminal).- external I.F. frequency translator available for connection to other I.F. outputs in the ranges 105-155MHz. 195-215MHz and 359-411MHz.- SV6 and CM3.
GPS receiver	<p>Trimble GPS</p> <ul style="list-style-type: none">- 8 or 12 parallel channels tracks up to 8 or 12 satellites, L1 C/A code with carrier filtering- Update rate maximum 10Hz- Accuracy typically less than 1 meter RMS- Time to first fix typically < 30 seconds- Interfaces<ul style="list-style-type: none">• NMEA messages: ALM, GGA, GLL, GSA, GSV, VTG, ZDA• TSP I/O user control <p>Other options: Ashtech Sensor II and G12. Motorola Encore. Novatel 3000. Trimble</p>
Power	<ul style="list-style-type: none">- SkyFix receiver = 3.5W- SkyFix receiver + GPS = 6W
Input supply voltage	10 to 36v DC

Appendix B: GPS Setup

As the GPS card has no direct user interface, configuration of the unit is achieved by software running on an external computer, called GPSSETUP. The Software resets the GPS card back to factory defaults and then alters the relevant settings in accordance with Fugro's recommendations. If alternative settings are required, other than the Fugro defaults, then a DSM.INI file can be created. DSM.INI will contain a list of the settings which have been changed in TSIP Format.

The programme is executed with the following command line:

```
<GPSSETUP Δ XXX>
```

where XXX indicates the GPS card type. Choose DSM, SK8, BD112 or G12.

The computer's COM port 1 is connected to the Mk3's port 3 for the configuration process.

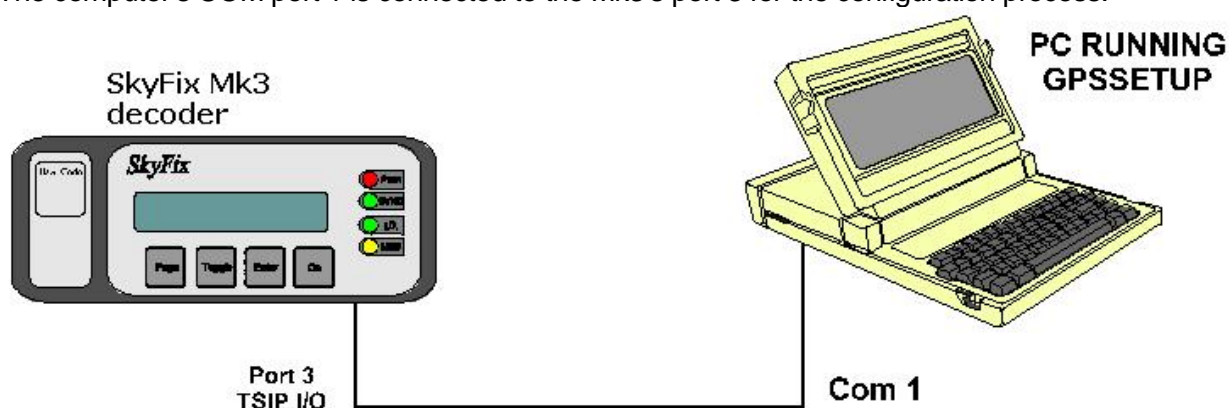

GPSSETUP configures the GPS card with the settings that are required. As a separate program it needs to be installed onto an external PC with its COM port 1 connected to port 3 on the SkyFix Mk3 Decoder.

The Fugro recommended settings are as follows:-

Fix mode	:	Full position/3-D
Dynamics mode	:	Air (high dynamics)
Elevation mask	:	10
Signal level mask	:	6
PDOP Mask	:	6
PDOP Switch	:	6
COM A	:	Input- RTCM SC. 104 v2 9600 8,n,1,CTS,RTS
COM A	:	Output- NMEA GGA + VTG 9600 8,N,1 NMEA GGA position to 6 decimal places NMEA VTG position to 6 decimal places
Differential mode	:	Manual DGPS
Differential time-out	:	25 sec.
Position fix rate	:	1 fix per second
Overdetermined mode	:	Weighted overdetermined (all available sats)

When the GPSSETUP is first executed it reads the default parameter from memory (displayed in green), or the ini file (displayed in orange) ready for downloading to the DSM. The screen will display a list of the parameters which the program is capable of altering. If any of the parameters have been



defined incorrectly, an error message will be displayed adjacent to the settings. Possible errors are incorrect parameter format or parameter value out of range.

```

Racal Survey Ltd.  GPS Rx Setup & Monitor Program (1UD 22.Nov.96)  11:00:35

                    Racal Survey Ltd.
                    GPS Rx Setup & Monitor Program
                    1UD 22.Nov.96

                    DSM

Loading DSM Defaults

Firmware Request          DEFAULT    1F,37,0          OK
Clear / Reset            N/A
Position Fix Mode        DEFAULT    22,4             OK
Operating Parameters     DEFAULT    2C,3,10,6,6,6   OK
Port A Configuration     DEFAULT    3D,11,11,19,7,5,1 OK
DGPS Mode                DEFAULT    62,1,2,-1       OK
Overdetermined Mode     DEFAULT    75,2             OK
Maximum PRC Age         DEFAULT    77,25           OK
NMEA Config.            DEFAULT    7A,0,0,5        OK
NMEA Config.            DEFAULT    7A,6,0,10,6     OK
NMEA Config.            DEFAULT    7A,6,1,8,4      OK
NMEA Config.            DEFAULT    7A,6,3,2        OK
Posn Fix Rate Config    DEFAULT    7C,0,1          OK

DSM Defaults Loaded

F1 Initialise  F2 Monitor  F10 Exit
    
```

Function keys in GPSSSETUP										
F2 Monitor	This page monitors the report packets which are continually output by the DSM. This will give the user status information about how the DSM is functioning.									
F1 Initialise	<p>This accepts a variety of inputs/outputs of various rates.</p> <p>The options are as follows:</p> <table border="1"> <tbody> <tr> <td>XMT Baud Rate</td> <td>50, 110, 300, 600, 1200, 2400, 4800, 9600, 19200, 38400</td> <td>sets the transmission baud rate</td> </tr> <tr> <td>RCV Baud Rate</td> <td>as above</td> <td>sets the reception baud rate</td> </tr> <tr> <td>Data Bits and Parity</td> <td>8-N, 7-N, 8-E, 7-E, 8-0, 7-0</td> <td>sets the ports parity and data bits</td> </tr> </tbody> </table>	XMT Baud Rate	50, 110, 300, 600, 1200, 2400, 4800, 9600, 19200, 38400	sets the transmission baud rate	RCV Baud Rate	as above	sets the reception baud rate	Data Bits and Parity	8-N, 7-N, 8-E, 7-E, 8-0, 7-0	sets the ports parity and data bits
XMT Baud Rate	50, 110, 300, 600, 1200, 2400, 4800, 9600, 19200, 38400	sets the transmission baud rate								
RCV Baud Rate	as above	sets the reception baud rate								
Data Bits and Parity	8-N, 7-N, 8-E, 7-E, 8-0, 7-0	sets the ports parity and data bits								



	Stop bits and H/W flow control	1. CTS-! RTS-Lo 1.CTS-! RTS-Hi 2.CTS-! RTS-Lo 2.CTS-! RTS-Hi 1.CTS-X RTS-Lo 1.CTS-X RTS-Hi 2.CTS-X RTS-Lo 2.CTS-X RTS-Hi 1.CTS-! RTS-Rx 1.CTS-! RTS-Tx 2.CTS-! RTS-Rx 2.CTS-! RTS-Tx 1.CTS-X RTS-Rx 1.CTS-X RTS-Tx 2.CTS-X RTS-Rx 2.CTS-X RTS-Tx
	Transmission language mode	Off, NMEA RTCM (SC-104) Packets 60+61 Packets
	Reception mode	Off RTCM (SC-104) Packets
	NMEA outputs	Toggle selected NMEA Strings on/off
F2 Set Unit	This section sends the configured parameters to the DSM after requesting the firmware from the unit, which is then displayed.	
F10 Exit	Exits the GPS SETUP Program	

DSM Defaults

Settings String	Description
1F	Request Firmware Information
1E	Clear Battery Backup & Reset
22,4	Position Fix Mode:: 4 = Full position (3-D)
2C,3,10,6,6,6	Operating Parameters : <ul style="list-style-type: none"> - Dynamics Code : 3 = Air - Elevation Mask : 10 degrees - Signal Level Mask : 6 - PDOP Mask : 6 - PDOP Switch : 6
3D,11,11,19,7,5,1	Serial Port A Configuration Command <ul style="list-style-type: none"> - XMT Baud Rate : 11 = 9600 - RCV Baud Rate : 11 = 9600 - Data Bits & Parity : 19 = 8 bits, no parity - Stop bits & h/w flow ctrl : 7 = 1 stop bit - Transmission language mode: 5 = NMEA - Reception language mode : 1 = RTCM(SC-104)
62,1,2,-1	DGPS Position Fix Mode <ul style="list-style-type: none"> - Mode : 1 = Manual DGPS (Diff.On) - RTCM Version : 2 = RTCM Ver.2 or PRC Type 9 - Ref.Station ID : -1 = Accept any station for use
75,2	Overdetermined mode : 2 = Weighted overdetermined mode



77,25	Maximum PRC Age : 25 seconds
7A,0,0,5	NMEA Interval & Message Mask <ul style="list-style-type: none"> - Subcode : 0 = Set NMEA interval & message mask - Interval : 0 = Use position fix rate - Message Mask : 5 = Enable GGA and VTG only
7A,6,0,10,6	NMEA GGA Message Options <ul style="list-style-type: none"> - Subcode : 6 = Message specific options - Message : 0 = GGA Options & Precision - Options : 10 = Default options - Precision : 6 decimal places
7A,6,1,8,4	NMEA GLL Message Options <ul style="list-style-type: none"> - Subcode : 6 = Message specific options - Message : 1 = GLL Options & Precision - Options : 8 = Default options - Precision : 4 decimal places
7A,6,3,2	NMEA VTG Message Options <ul style="list-style-type: none"> - Subcode : 6 = Message specific options - Message : 3 = VTG Speed Precision - Precision : 2 decimal places
7C,0,1	Position Fix ASAP Fix Rate <ul style="list-style-type: none"> - Subcode : 0 = Set ASAP fix rate - ASAP Rate : 1 Hz

SK8 Defaults

Settings String	Description
1F,37,0	Request Firmware Information
1E	Clear Battery Backup & Reset
BB,3,4,1,3,2,10,6,6,6,25	Receiver Configuration <ul style="list-style-type: none"> - Subcode : Always 0x03 - Operating Dimension : 4 = Full Position (3-D) - DGPS Mode : 1 = DGPS Only - Dynamics Code : 3 = Air - Track Mode : 2 = Weighted all-in-view - Elevation Mask : 10 degrees - Signal Level Mask : 6 - PDOP Mask : 6 - PDOP Switch : 6 - DGPS Age limit : 25 seconds
BC,1,7,7,3,0,0,0,8,4	Communications Parameters <ul style="list-style-type: none"> - Port No.: 1 = Port 2 - Input Baud Rate : 7 = 9600 - Output Baud Rate : 7 = 9600 - Data Bits : 3 = 8 bits - Parity : 0 = None - Stop Bits : 0 = 1 bit - Flow Control : 0 = None - Input Protocol : 8 = RTCM - Output Protocol : 4 = NMEA

Appendix C: Pin layout Power, Output Ports and Antennae

Pin layouts:

	Connector Type	Pin connections
Power	2 pin fischer S103z5116.71s	pin 1 -ve DC input pin 2 +ve DC input
Port 1+3	9-way 'D' male	Pin 1 No connection Pin 2 Port 1 RS232 Transmit (RS485TX-) Pin 3 Port 1 RS232 Receive (RS485RX-) Pin 4 No connection Pin 5 Ground Pin 6 (Port 1 RS485TX+) Pin 7 (Port 1 RS485RX+) Pin 8 Port 3 RS232 Transmit Pin 9 Port 3 RS232 Receive
Port 2 + 4	9-way 'D' male	Pin 1 No connection Pin 2 Port 2 RS232 Transmit (RS485TX-) Pin 3 Port 2 RS232 Receive (RS485RX-) Pin 4 No connection Pin 5 Ground Pin 6 (Port 2 RS485TX+) Pin 7 (Port 2 RS485RX+) Pin 8 Port 4 RS232 Transmit Pin 9 Port 4 RS232 Receive
GPS antenna	50 Ohm TNC	GPS signals from a standard GPS L1 Compact Dome Antenna. You only need to connect a GPS antenna if a GPS card is fitted inside the Mk3 Decoder.
Differential antenna	50 ohm BNC	Input from Starfix network.
Signal strength	SMB connector	0-3.5V output to indicate the current signal strength of the signals. This is normally connected to an antenna controlling unit.
10 MHz output	SMB connector	Outputs a 10 MHz reference frequency for use with an I.F. translator for Inmarsat terminal interfacing.

Note - RS485 can be configured internally. This is only used where data runs are in excess of 30 metres.

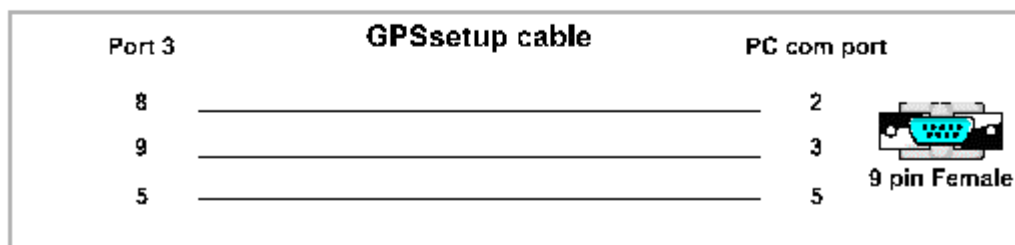
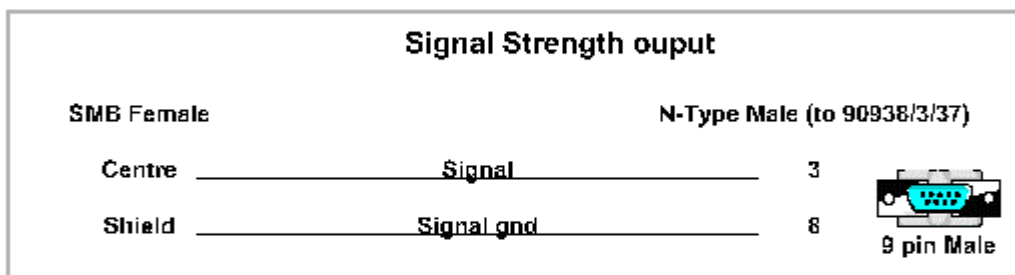
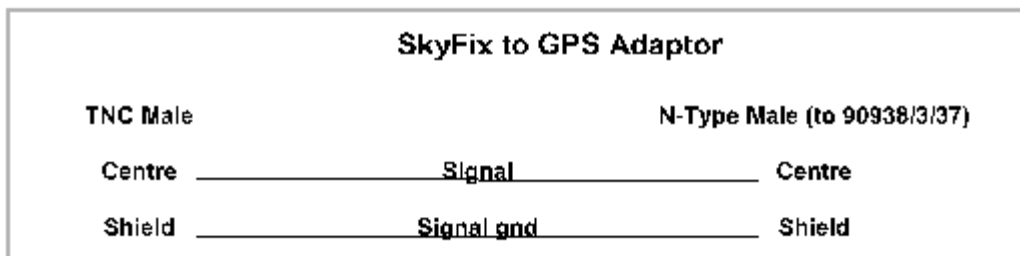
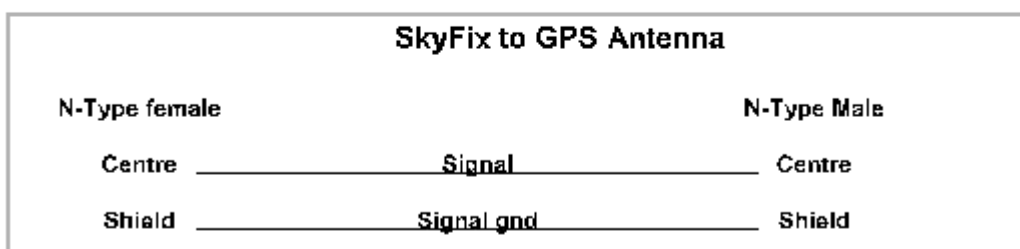
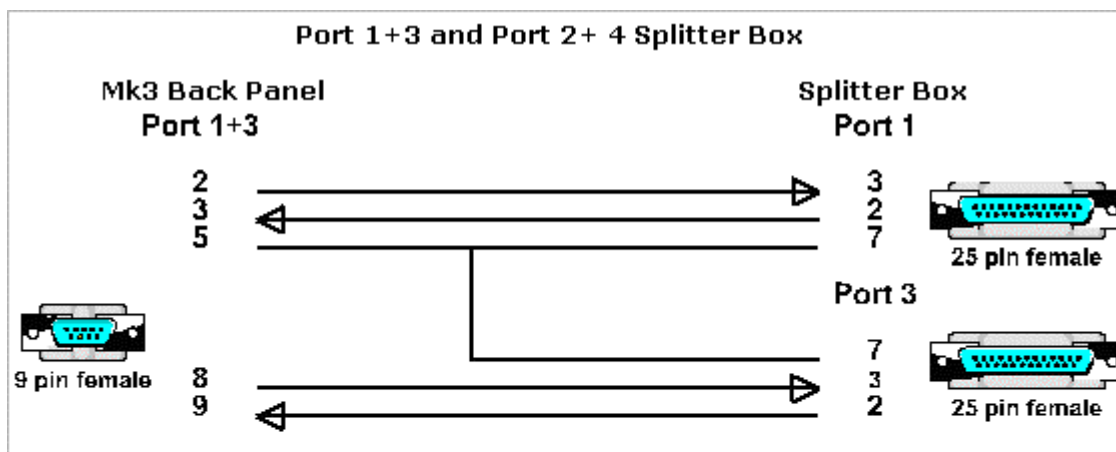

Appendix D: Trouble shooting

Fugro's SkyFix Mk3 Decoder is designed and manufactured to exacting standards and, once installed and operated correctly, should provide prolonged trouble-free service.

The information contained in this short chapter on trouble shooting is restricted to such testing that can be undertaken in the field.

There are no user-adjustable controls or user-serviceable items within the receiver. Units should be returned to the manufacturer for repair. To expedite repairs, the following information should be included with the returned unit:

- Detailed fault description and operating conditions. (Please complete the appropriate QA/NCR Form)
- Contact name with telephone/fax numbers.

Note:

The unit is protected against current overload by a resettable thermal fuse. This is not accessible to the user.

Fault Finding Assistance

The following diagnostic procedures enable the user to carry out simple fault finding on the system.

Fault	Reason	Remedy
Unit off completely.	Blown fuse. MKIII receivers do not need fuses as the unit is protected against short circuits and incorrect polarity.	Check inline power lead fuse (if fitted) and replace fuse as necessary.
	Faulty supply.	Check supply for 10 - 36V DC output. Check battery is properly charged.
	Incorrect voltage polarity.	Ensure red cable is connected to +ve and blue cable to -ve.
Red Lock LED on downconverter is off.	No power to downconverter.	Check the continuity of the IF interconnect cable. Replace if necessary. If the downconverter is in doubt, return the unit to Fugro.
No signal. Status page: 0V signal	Insufficient time allowed for unit to warm up.	Allow 20 seconds for initial warm up period.
Strength BER=E-0 or E-1 r1 ◆ LEDs: SYNC is off.	Antenna not connected.	Check the antenna connection is secure. Refer to the maps at the back of this manual for correct antenna elevation adjustment.

	The Inmarsat satellite is not visible to the antenna.	Relocate the antenna.
No signal Status page: 0V signal strength BER=E-0 or E-1 rl ◇ SYNC LED is off.	If the S/W version on the Demodulator menu reads VERS *** then communications between the demodulator and decoder have failed. This could be due to a short power break.	Switch the unit off for ten seconds then reactivate. Check the power cable is secure particularly if the unit is powered from a battery source.
Signal intermittent Status page: low signal strength BER=E-1	Incorrectly sited or tuned antenna.	Check antenna location and connections. Retune rod antenna elevation setting if necessary.
Intermittent ◇/◆ lock flags SYNC LED intermittent.	Poor antenna connection	Check connections are secure and not cross threaded.
I.D. LED off or flashing SYNC LED flashing. Status page: All OK	The unit ID has not been received.	If the unit has not obtained the ID received after 15 minutes, contact Fugro.
	Port 1 not enabled.	Enable port 1 for RTCM.
	Reference station not selected	Select desired reference station ID, deselect all remaining stations.
	Incorrect data format selected.	Ensure data format of port 1 is the same as that set in the GPS receiver.
	GPS receiver RTCM input disabled.	Refer to GPS receiver user guide to enable input port for RTCM.
Loud buzz from receiver and all the LEDs are on. Main LCD backlight may also strobe.	IF cable between the receiver and the downconverter is short circuit.	Switch off power. Check and replace interconnect cable if necessary. If cable is found to be OK, the fault may lie in the downconverter.
Unable to switch off receiver using the Power Control menu.	Power relay is faulty.	The unit is otherwise unaffected and will operate normally. Power can just be disconnected until the unit can be returned to Fugro for repair.

Appendix E: Interfacing Mk3 Decoder to Starfix.IOWIN

The following four pictures show examples of interfacing the SkyFix Mk3 Decoder with GPS to Starfix.IOWIN.

```

NMEAGpsIn - NMEA GPS - COM 1 - 9600,N,8,1
$GPGGA,111327.00,5205.736472,N,00424.287310,E,0,03,2.7,81.33,M,0.00,M,0.0,0000.0,M,0.0,0000.0,0000.0000,000.0,M,0.0,0000.0,A*69J0
Time: 792155607.0 Lat: 52.0956 Lon: 4.4048 Quality: Invalid Stn: 0

$GPVTG,133.5,T,0.000,14,N,000.25,K,A*46J0
SOG: 0.1 kn COG: 133.5 True
    
```

Figure 10 Port 1: NMEA Output

```

RTCMIn - RTCM In - COM 1 - 9600,N,8,1
Station 16 Zcount 1300 Health 0
Type 1 Sats = 8 Type 9 Sats = 0
Type 3 6 27 7.239 N 3 23 27.205 E 103.5
    
```

Figure 11 Port 2: RTCM Output

```

TrimDSM - TrimDSM - COM 2 - 9600,0,8,1
472459 6 Sats 22,18,16,15,6,21
Ephemeris for PRN 21
    
```

Figure 12 Port 3: Trimble DSM output

```
SuperIn - Super - COM 2 - 9600,N,8,1
1321 Sites = 14 from 31 Sats = 18 CBMF 18 bytes :?ZZ
Position for Station 480 T15 IONO for Station 16
Map 229,410,101,95,45,144,11,19,0,620,0,571,16,290,293,0,280,630,580,114,530,371,400,351,431,500,260,690,60,521,4
Almanac Type 55
Time = 792155600 HP = 792155526

1298 Glonass for Station 630n 1480943135
792155526 HP Map 20 Stations <16,290,371,521,571,630,580,530,620,351,431,480,0,400,576,410,690,500,260,144> 32 S
792155560 HP 15 Sats
329 HP Clock 1,2,3,4,5,6,7,8,9,10,11,13,14,15,16,17,18,19,20,21,22,23,24,25,26,27,28,29,30
472363 HP Orbits 1,2,3,4,5,6,7,8,9,10,11,13,14,15,16,17,18,19,20,21,22,23,24,25,26,27,28,29,30
```

Figure 13 Port 4: Super Compressed

Appendix F: Toolkit

The Toolkit is a program which allows extended configuration of the Mk3 Decoder. The program communicates with the Mk3 Decoder through Port 3 of the Mk3 Decoder, when the format for Port 3 is set to “REM”.

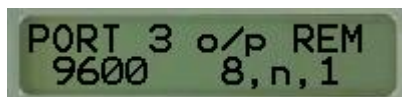

Make sure you press Enter after selecting the option REM.

The Toolkit is also equipped with Password protected menu's for subscription, etc. The Toolkit is usually only operated by trained warehouse engineers for maintenance purposes. As such no extended manual is included here.

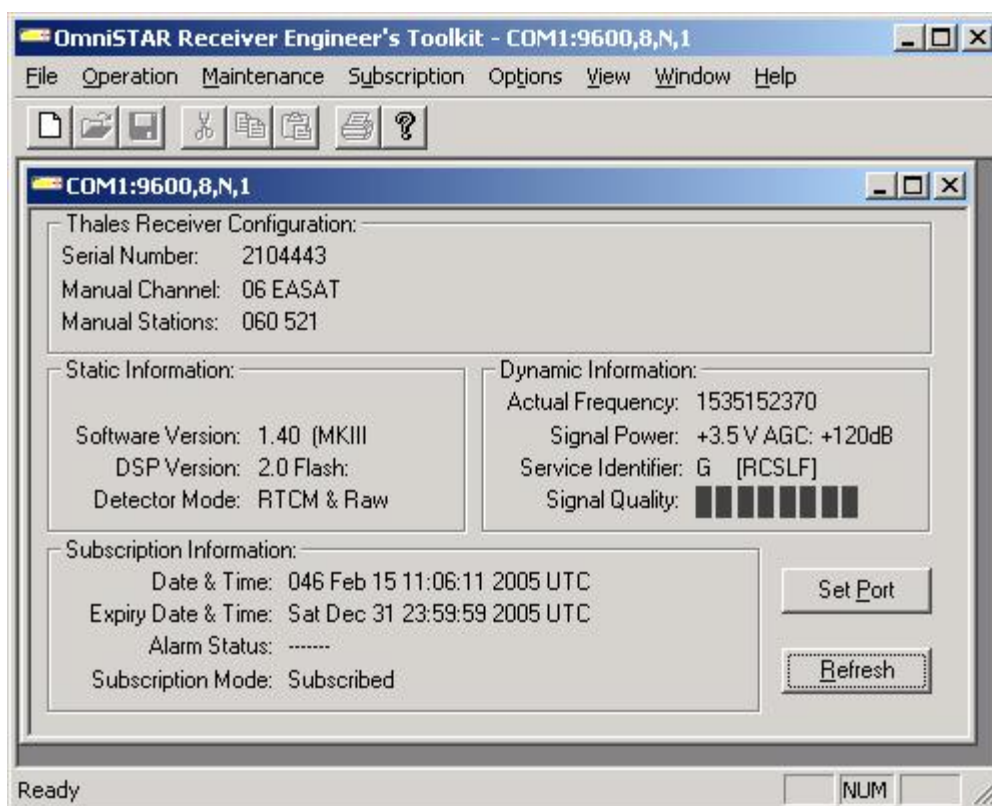

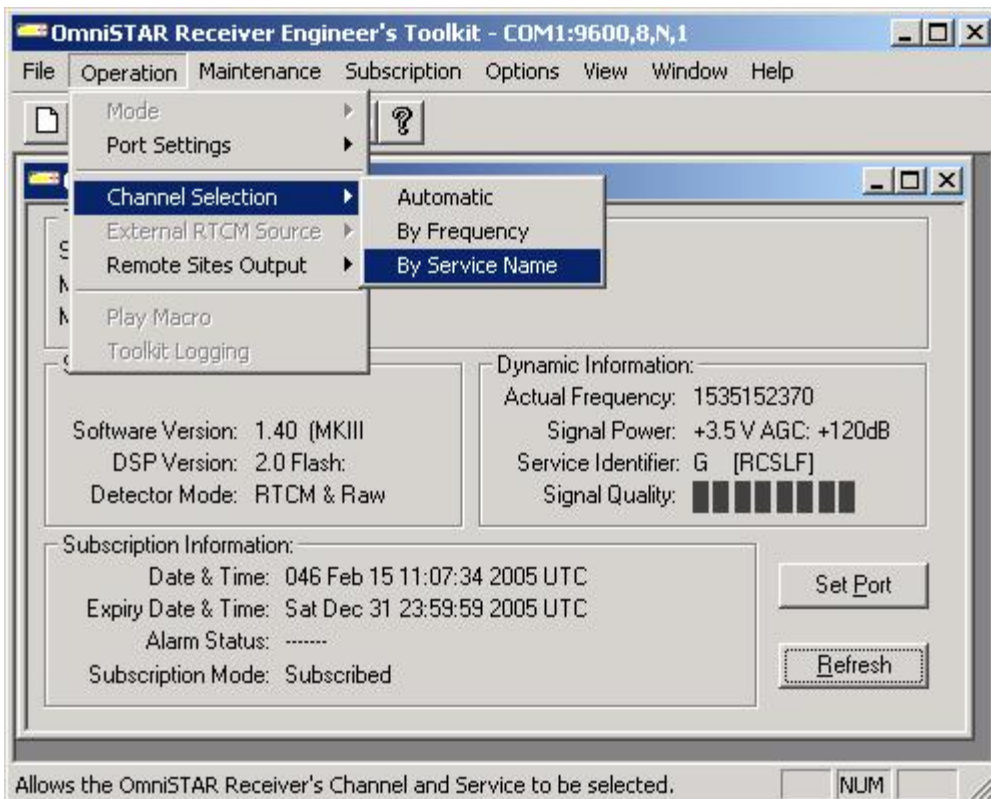
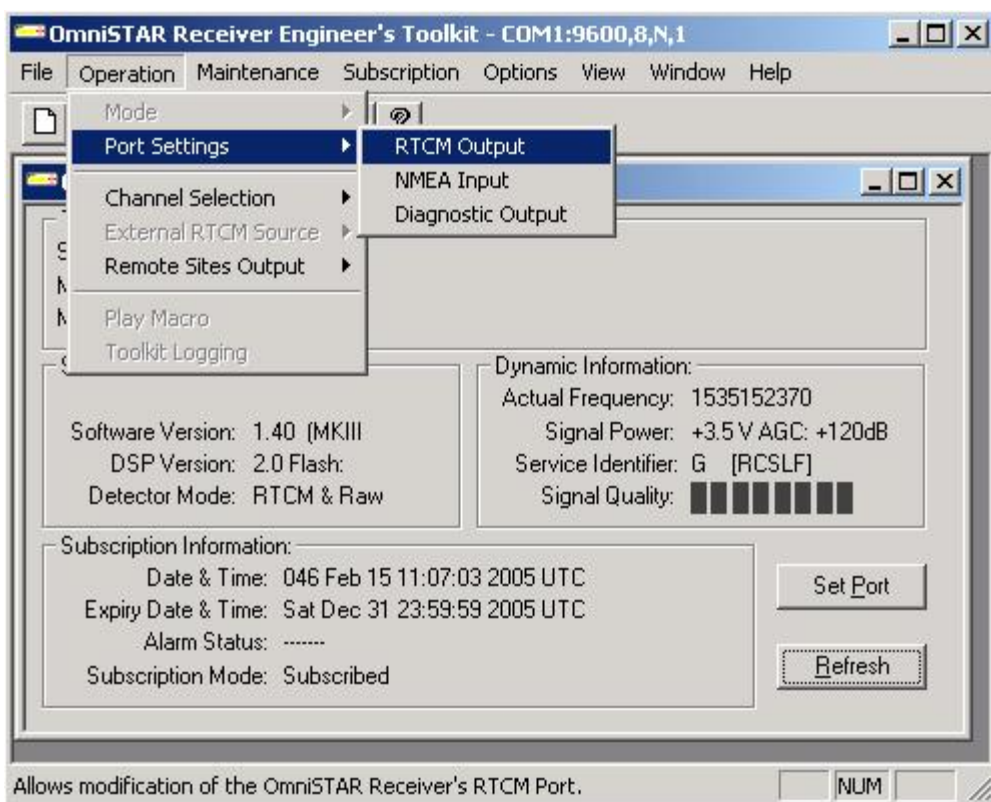

Appendix G: Available Uplink Channels

At moment of publication, the following channels are available for selection in the SkyFix Mk3 through the channel selection menu:

Satellite Channel	Frequency	Symbol Rate	Inmarsat/Spot
Eik AOR(e)	75.09	1200	Inmarsat
Eik IOR	75.09	1200	Inmarsat
AF SAT	75.14	1200	Spot
AP-SAT	75.1375	600	Spot
Perth POR	75.115	1200	Inmarsat
EA-SAT	75.1525	1200	Spot
AM-SAT	75.1375	1200	Spot
Houston AMSC-W	71.489	1200	Spot
Houston AMSC-C	74.497	1200	Spot
Houston AMSC-E	76.825	1200	Spot
Perth Optus	78.51	1200	Spot
Houston AOR-W	75.0975	1200	Inmarsat

See next page for Coverage Maps

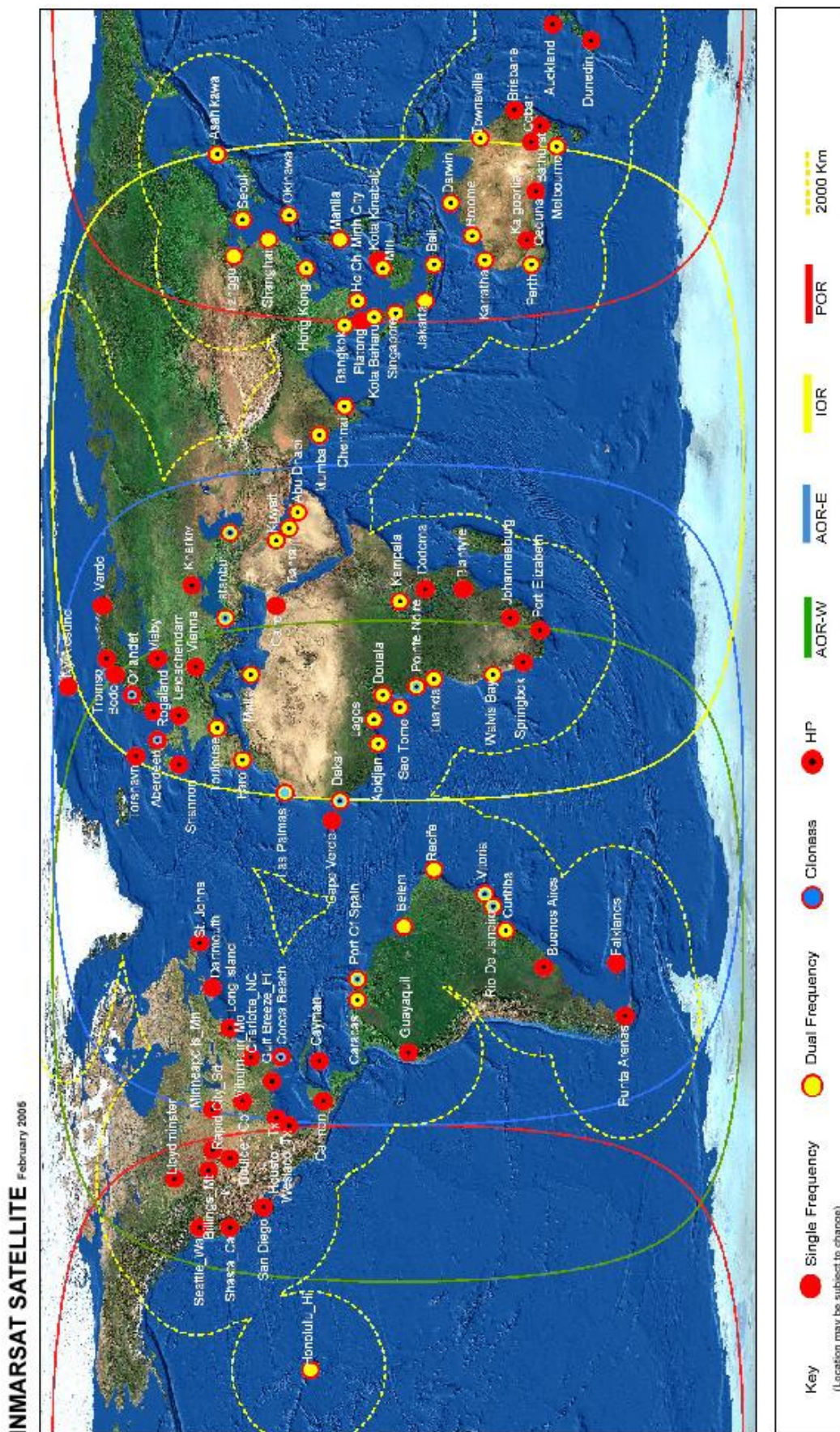

Figure 14: Inmarsat satellite Coverage Map

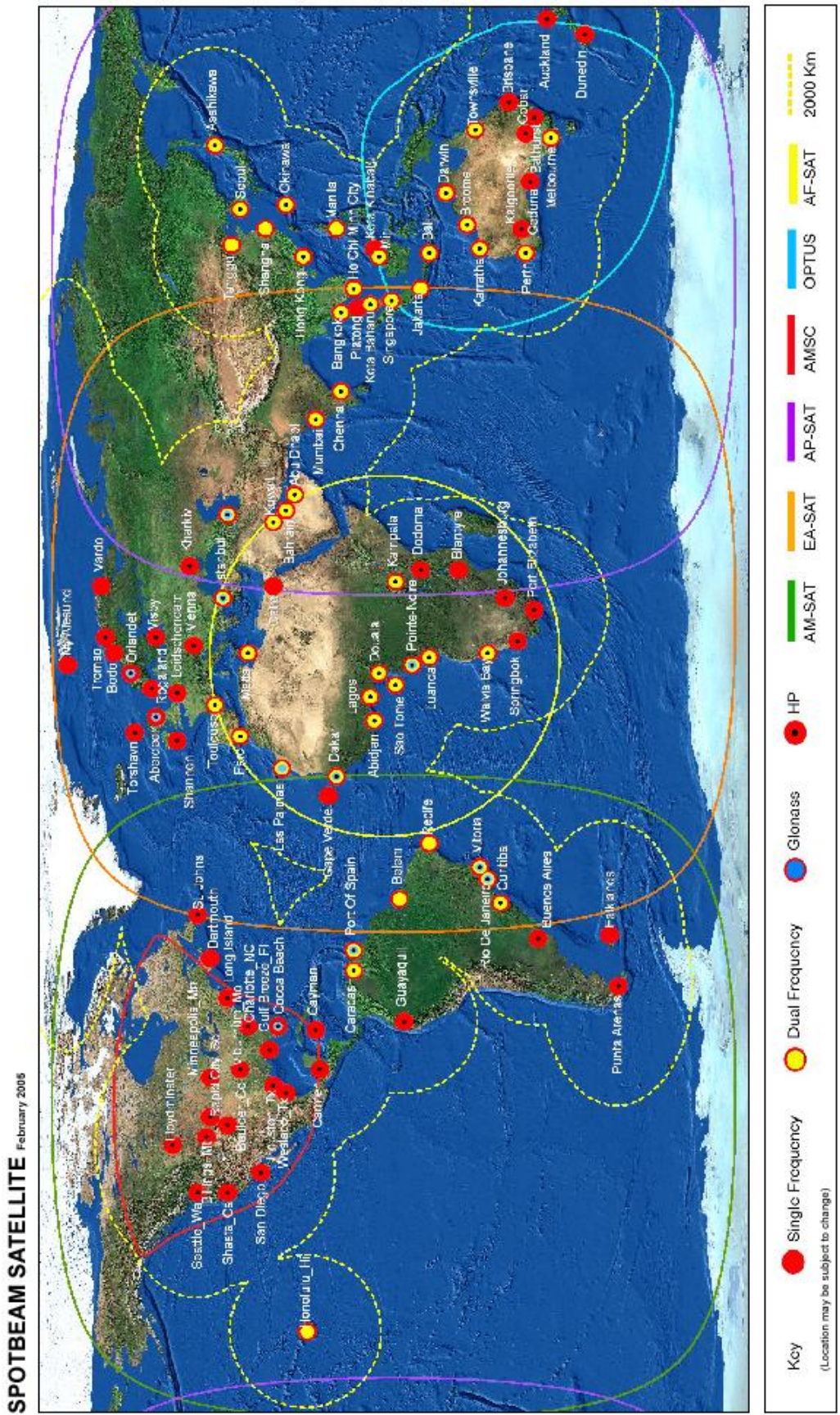

Figure 15: Spotbeam Satellite Coverage Map