



# Fugro

## MultiFix 4 Positioning & QC software description

### - 22 November 2004, Issue 3 -

## 1. INTRODUCTION

MultiFix 4 is Fugro's fourth generation real time position computation and QC program. It is an integral part of the SkyFix XP and SkyFix Premier service but can also be used with the standard SkyFix service. MultiFix 4 was released to support Fugro latest generation positioning service, SkyFix XP.

MultiFix 4 is one of a series of programs, which includes other tools and utilities with a similar user interface and layout structure, like static, and dynamic position comparison programs, a correction monitors program, a terminal program and a replay utility.

MultiFix 4 takes in Almanac, Ephemeris and Raw Code and Carrier measurements from a single or dual frequency GPS receiver (or, for replay, from logged files).

It takes in RTCM SC104 Version 2 differential correction messages from one or more RTCM Correction delivery systems. It takes in Fugro Proprietary RTCM Type 11, 48, 49 and 50 orbit and clock corrections for use with SkyFix XP.

It takes in RTCM Type 15 or Fugro Proprietary RTCM Type 55 Ionospheric range corrections generated at selected SkyFix Premier reference stations and broadcast via the Fugro global network of high and low power L-Band beams.

Some of the key features are:

- There is no limit on the number of RTCM correction delivery systems
- There is no limit on the number of RTCM differential reference stations
- There is no limit on the number of computations
- Each computation can employ corrections from any combination of reference stations available (SkyFix XP only requires one correction source as it is not restricted to individual reference stations)
- Uses the EGM96 geoid/spheroid separation model.
- The computations with statistical evaluation based upon the UKOOA recommendations
- Multiple XP Correction sources
- Capable of logging and replaying data
- There is no limit on the number of outputs
- There is no limit on the number of view windows
- The view windows can be customised
- Extra user-specific NMEA output formats can be defined
- TCP/IP communication via sockets for GPS, RTCM and position data transfer between networked computers

MultiFix 4 has been designed in a modular fashion such that data is passed between modules as if over a computer network. The core module MultiFix 4 performs the computation of position. Additional modules are available and more will be made available in the future. While a single computer can be used, the various modules will equally be able to be run on different computers, provided there is a network interconnection.



The RTCM corrections that are generated at reference stations are contaminated by a variety of error components, one of which is Ionospheric delay. The Ionospheric delay is currently more variable because of greater sun spot activity. MultiFix's standard computation uses the Klobuchar Ionospheric delay model. This model is updated periodically but is not responsive to the current short-term variability. MultiFix 4 has an additional calculation option when working with dual frequency receivers and in receipt of Type 15 or 55 RTCM messages. With dual frequency receivers, estimates can be made of the Ionospheric delay by examining the differences between the measurements from the two frequencies. If the same procedure for estimation of Ionospheric delay is performed at the reference stations and on the mobile, both the RTCM corrections and the pseudo-ranges can have the Ionospheric delay removed, effectively providing an Ionospheric-Free DGPS position solution.

As with all Differential positioning systems, they are restricted by range from reference stations, typically 2000km. Fugro has overcome this limitation with the launch of SkyFix XP.

SkyFix XP approaches the differential technique from a totally different perspective. The global network of reference stations is used to track all satellites continuously throughout their orbit. These global observation sets are then combined into a single correction process. This process identifies, isolates and measures each individual source of error and provides a complete set of orbit corrections for each GPS satellite. As such this measurement set can be used at any location, regardless of distance to a reference station, making the system truly global

The remaining tropospheric and ionospheric error sources are estimated or eliminated at the user end. The Tropospheric error is removed utilising a Tropospheric modelling technique as part of the position calculation within MultiFix 4. Whilst the ionospheric delay is eliminated by using a dual frequency GPS receiver at the users location. Multipath and receiver noise at the users location are limited by using the carrier phase observations.



## 2. MINIMUM HARDWARE REQUIREMENT

MultiFix 4 requires a PC running Windows NT, Windows 2000 or Windows XP. A 600 MHz Pentium III (or Equivalent) with 128MB RAM is recommended. For configurations using 15 (total for all RTCM sources) or more reference stations it is recommended that available memory be increased to 256MB Ram. Further, a graphics resolution of at least 1024 by 768 pixels is recommended in order to achieve maximum clarity of all the graphics displays.

For the installation of the applications, ideally the PC should have a CD-ROM drive. It is possible to create and install from floppies but beware that 8 floppies are required.

MultiFix 4 needs a single frequency GPS receiver, such as the Ashtech DG16, Trimble 4000DS, BD112, DSM or DSM212, to run in standard SkyFix mode and a dual frequency GPS receiver, such as the Ashtech ZX-Sensor or Trimble MS750/BD750, 4000 SSE/I to run in SkyFix XP and Premier mode.

Assuming data is not being input or output over network sockets, as a minimum the PC needs 1 COM port for two-way communications to the GPS receiver and a second COM port for the input of RTCM corrections. Given that the second port is for input only, by using a special breakout cable, the same COM port used for the RTCM input can also be used for the output of position messages.

If there is more than one RTCM delivery system or data is to be output on several ports, then additional COM ports will be required. These can be any proprietary asynchronous serial board (or PCMCIA card) the Windows drivers for which, allow the board's/card's ports to be mapped as additional COM ports.

### 3. HARDWARE INTERCONNECTION

#### 3.1 SkyFix Single Frequency

The following diagrams outlines the hardware requirements and interconnections for a standard single-frequency SkyFix setup using Fugro MK3 or MK5 decoders and an Ashtech DG16 GPS receiver.

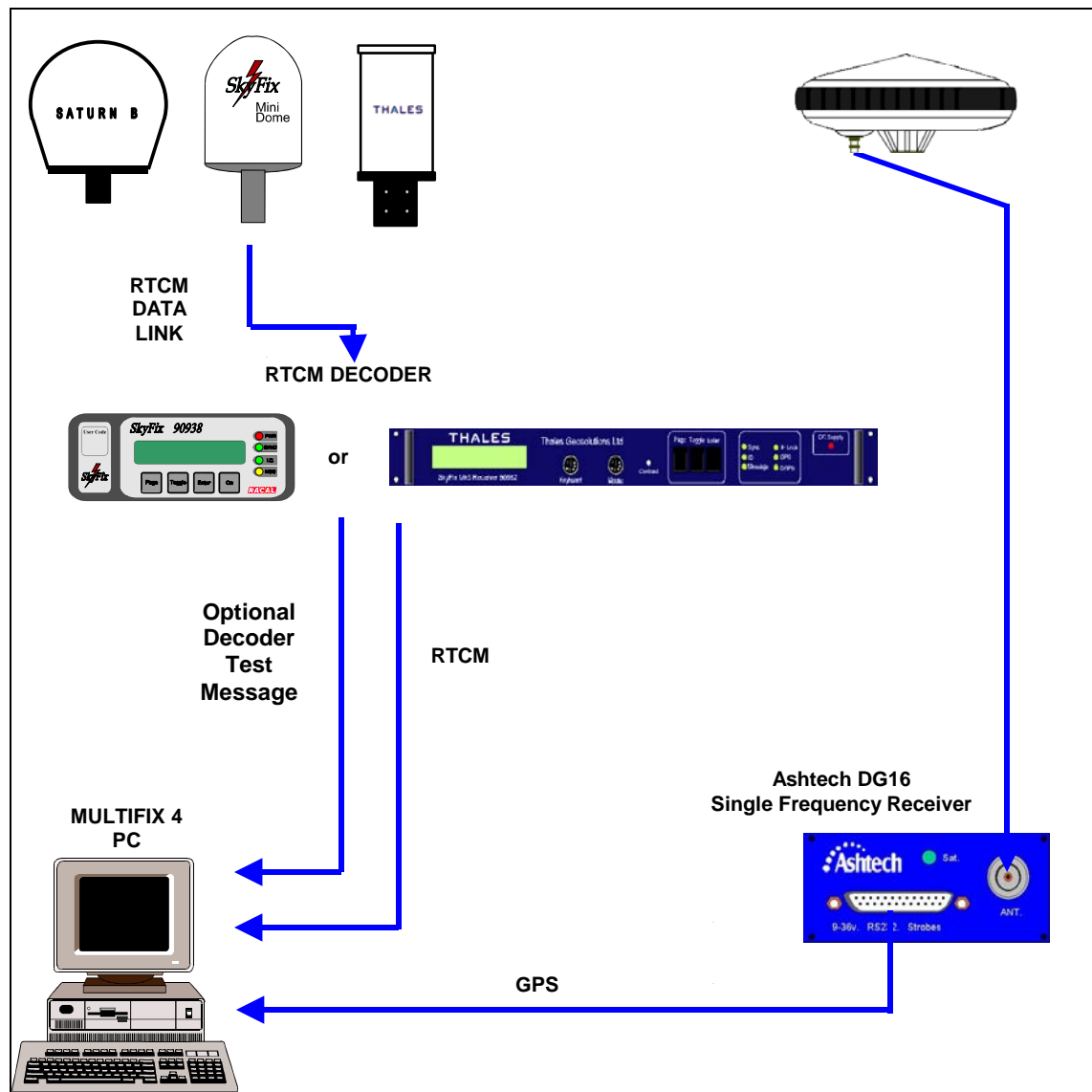

Figure 1 Example Interconnection with an Ashtech DG16 Receiver

### 3.2 SkyFix XP / Premier Dual - Frequency

The following diagrams outlines the hardware requirements and interconnections for a SkyFix XP or Premier dual-frequency setup using an Ashtech ZX Sensor.

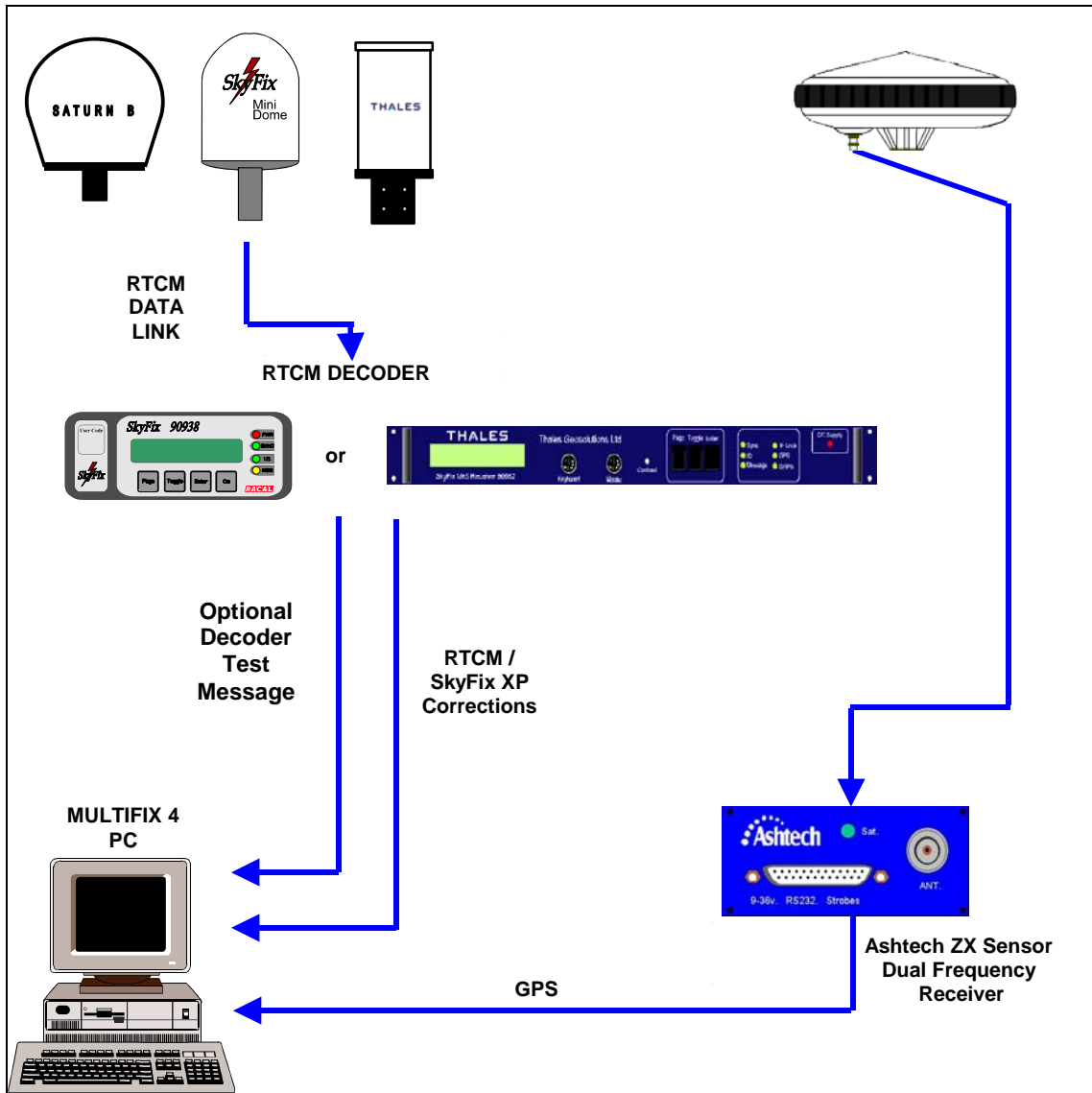

Figure 2. Example Interconnection with Ashtech ZX Sensor

The following diagrams outlines the hardware requirements and interconnections for a setup using an embedded Ashtech DG14/16 receiver.

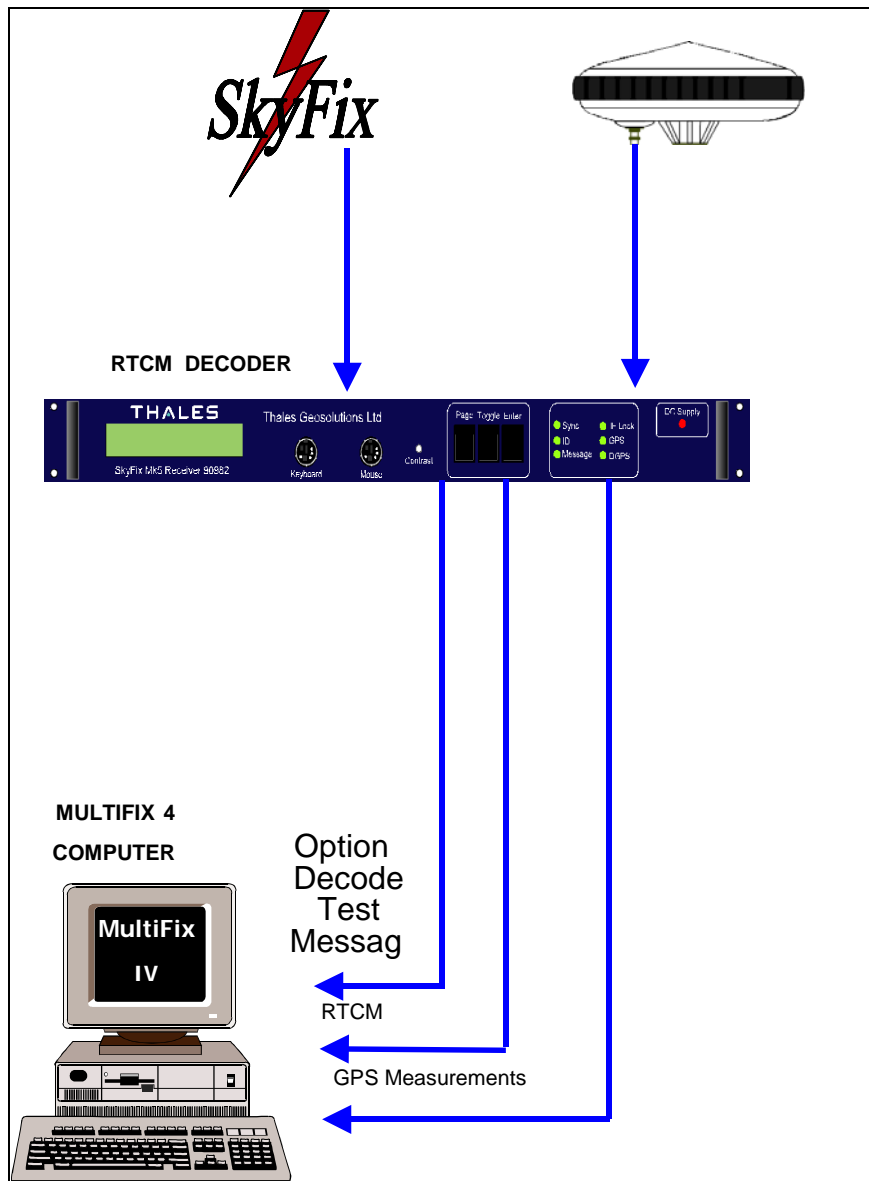

Figure 3 Example Interconnection with MK5 and internal GPS Receiver



#### **4. MULTIFIX 4 POSITIONING AND QC DISPLAYS**

MultiFix 4 has a large number of features to accommodate the user requirements of highly accurate positions with QC information and outputs in different formats. MultiFix 4 runs in a Windows environment, which allows the user to design his preferred screen layout by opening, sizing and placing the numerous displays that are available. Examples of the various displays can be found below. Other features are:

- unlimited number of single frequency and dual frequency DGPS calculations
- unlimited number of RTCM inputs
- unlimited number of position outputs
- user configurable graphical displays
- user defined NMEA outputs
- TCP/IP communication via sockets for GPS, RTCM and position data transfer between networked computers

This MultiFix 4 display shows:

- a map of the work area with the location of the user and the available reference stations
- the SNR values of the GPS satellites
- constellation plots of the corrections of each of the reference stations
- a position display of one of the solutions
- terminal displays of the GPS raw data stream and one of the RTCM input streams
- latency and correction quality for each of the available reference stations

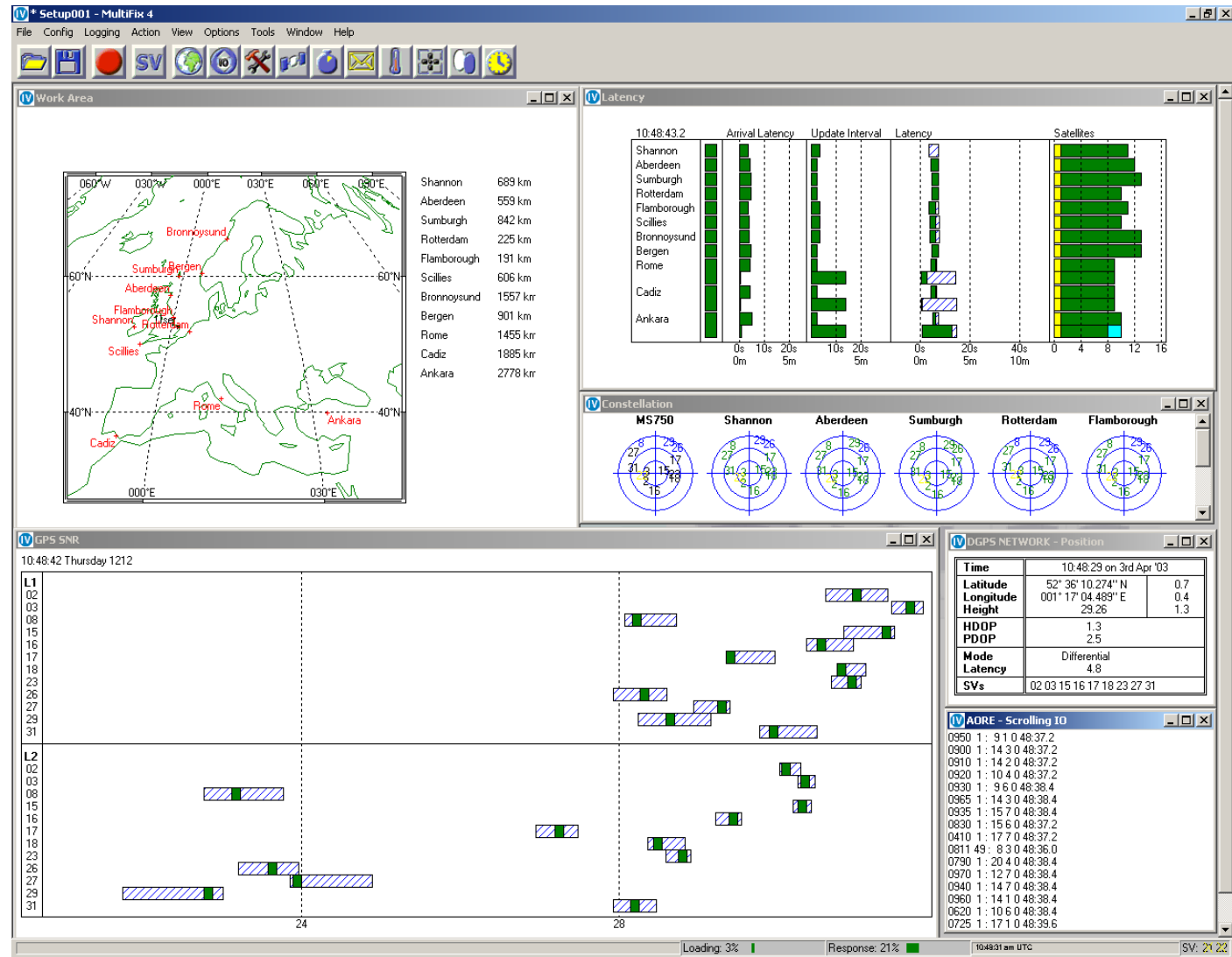



This MultiFix 4 display shows:

- satellite residual plots and solution quality information
- position offsets and error ellipses
- summary of calculation status of all solutions with unit variance and quality indicator

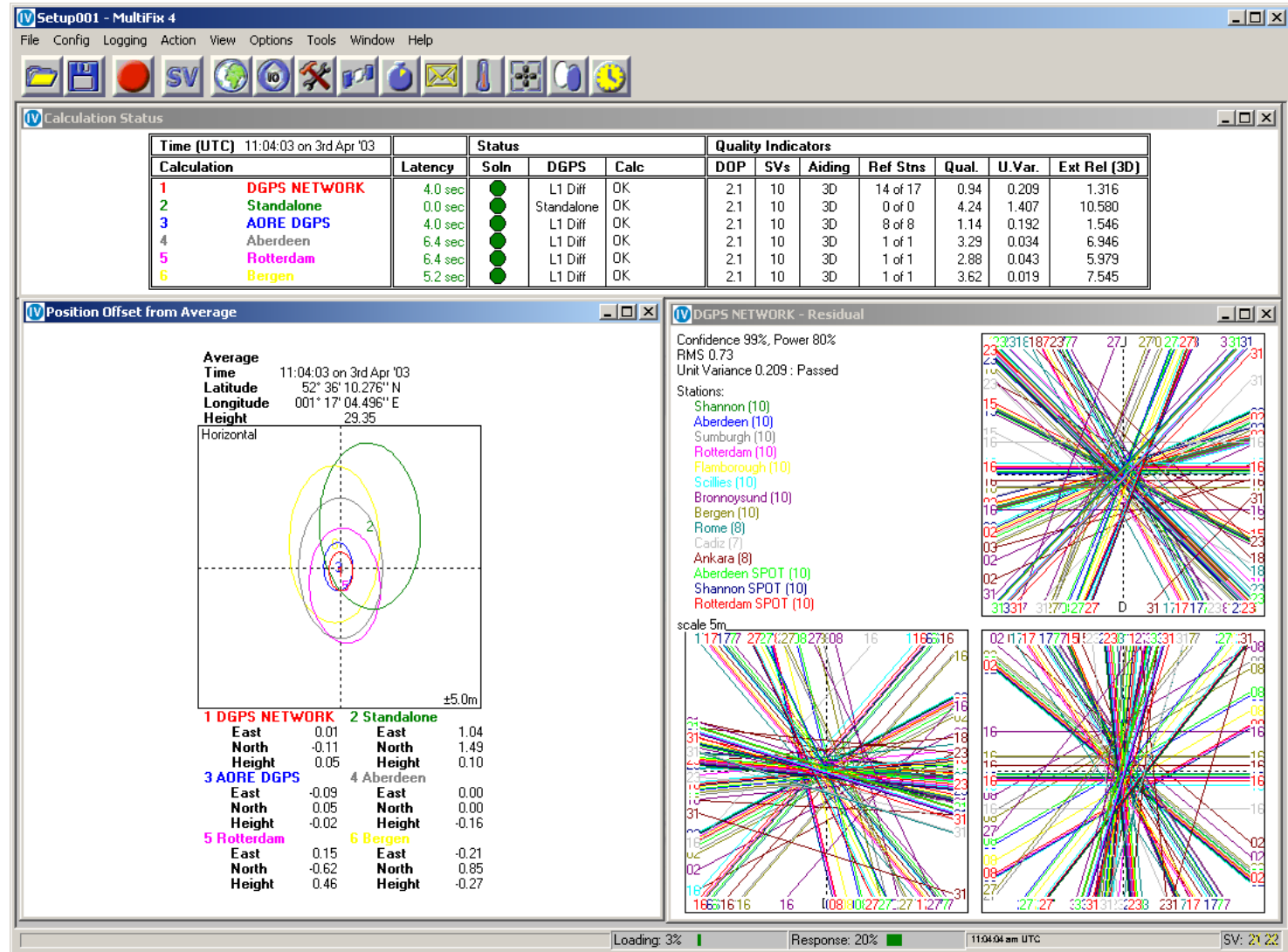

This MultiFix 4 display shows:

- Position, Geometry and Latency Time Series Plots
- 2D Cumulative Frequency histogram
- Solution position offsets and error ellipses

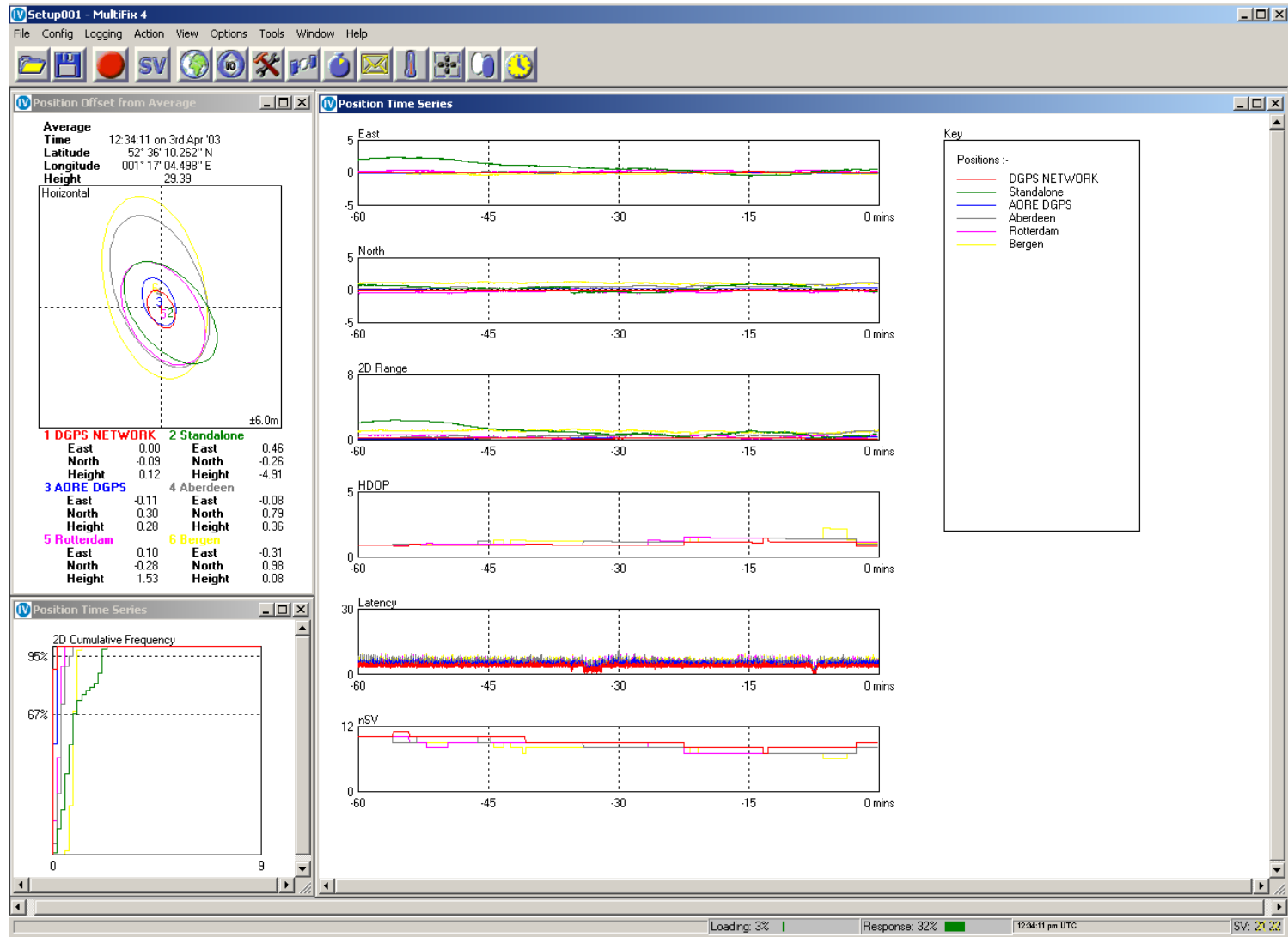

This MultiFix 4 display shows:

- the Code-Carrier filter graphs of the L1 and L2 GPS observations
- the front panel of the GPS receiver
- the SNR values of the GPS satellites
- the activity of the Code-Carrier filter

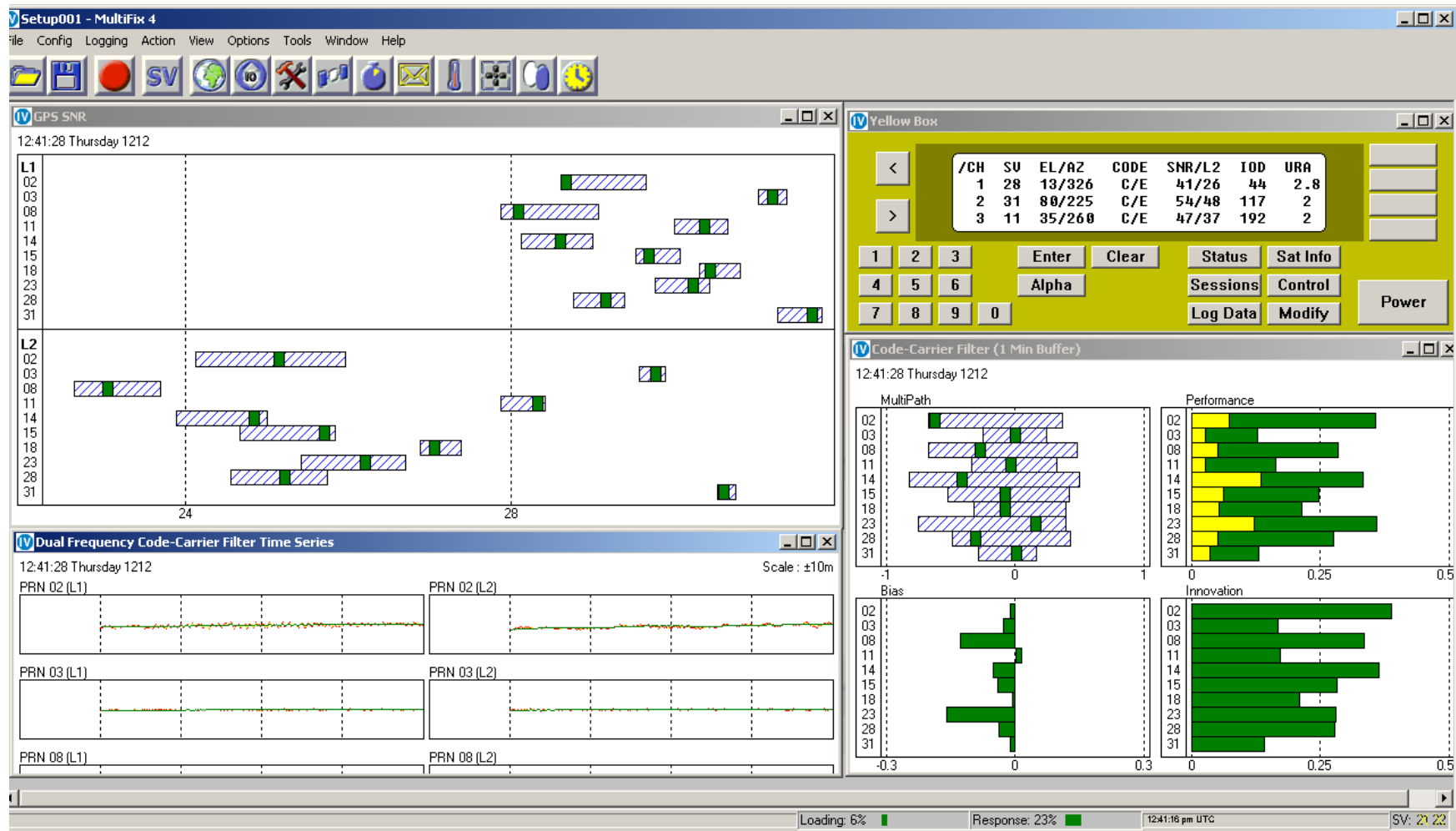

This MultiFix 4 display shows:

- constellation plots of the corrections of each of the reference stations
- table with differential station correction information
- hardware processor Performance table

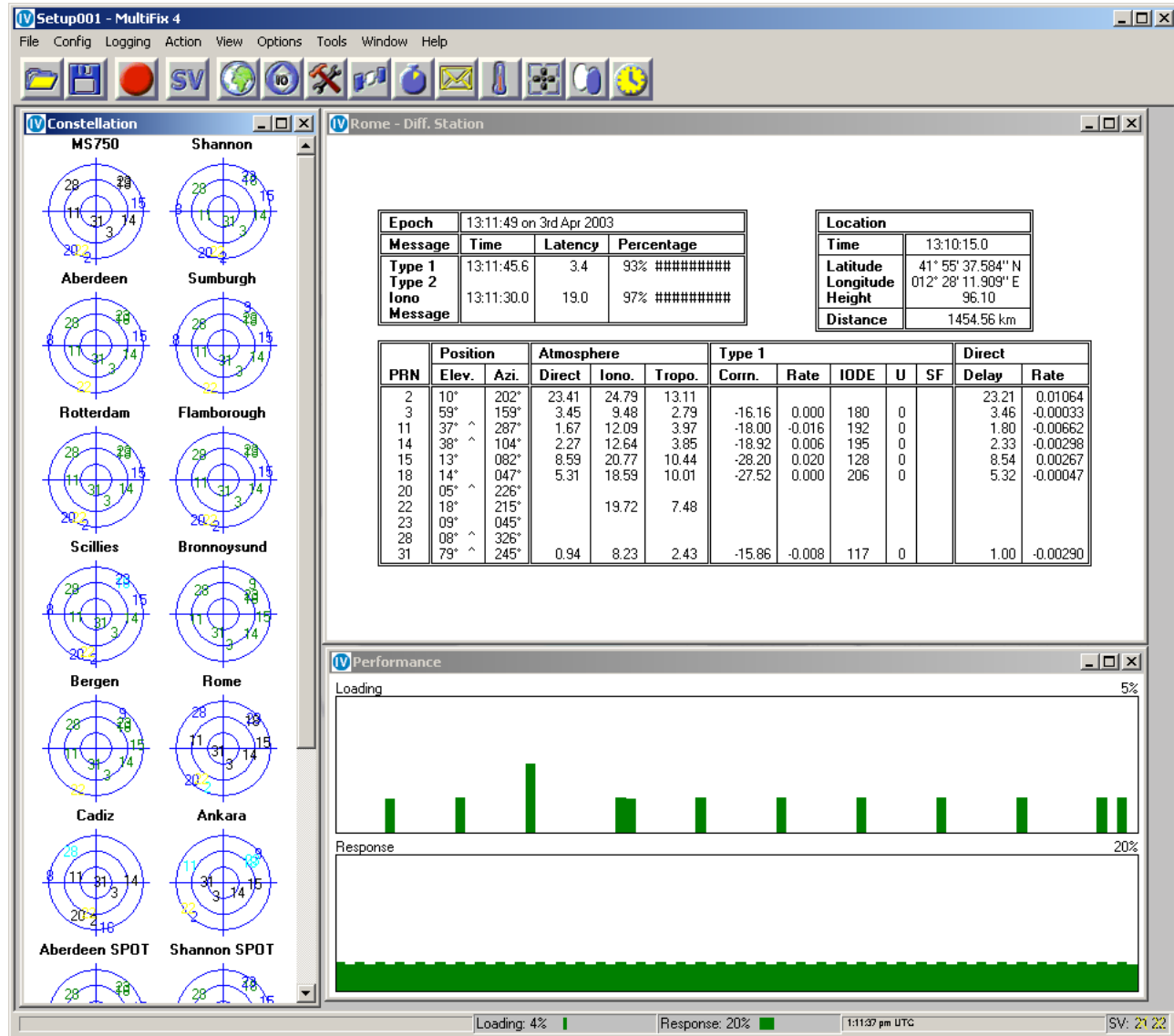

This MultiFix 4 display shows:

- Almanac View for a single station solution
- SV disable/enable panel

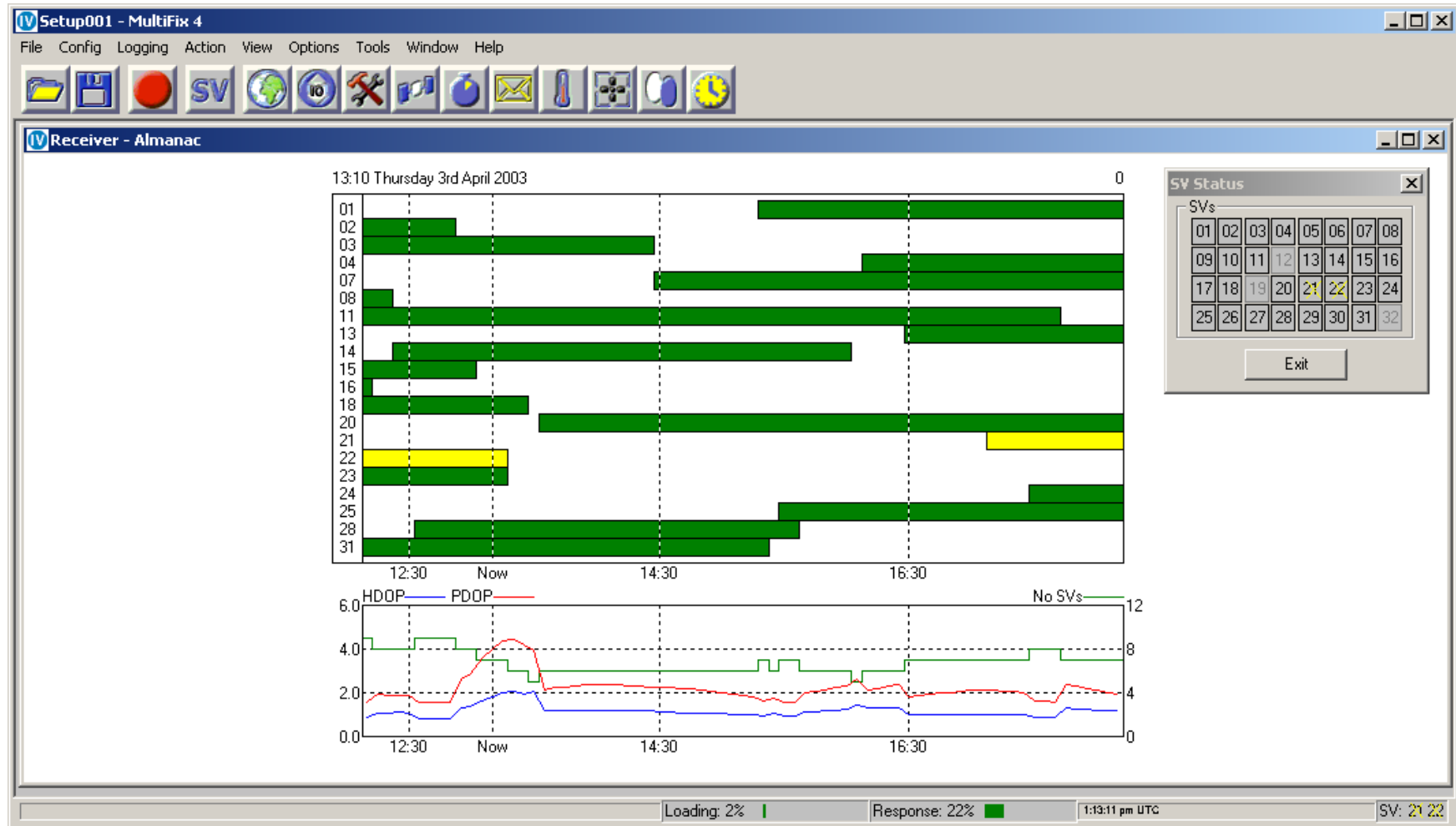

This MultiFix 4 display shows:

- Calculation Status
- Table of UKOOA statistics of Pseudo-Range Correction residuals
- Time series plots of UKOOA statistics of calculations
- Solution position offsets and error ellipses

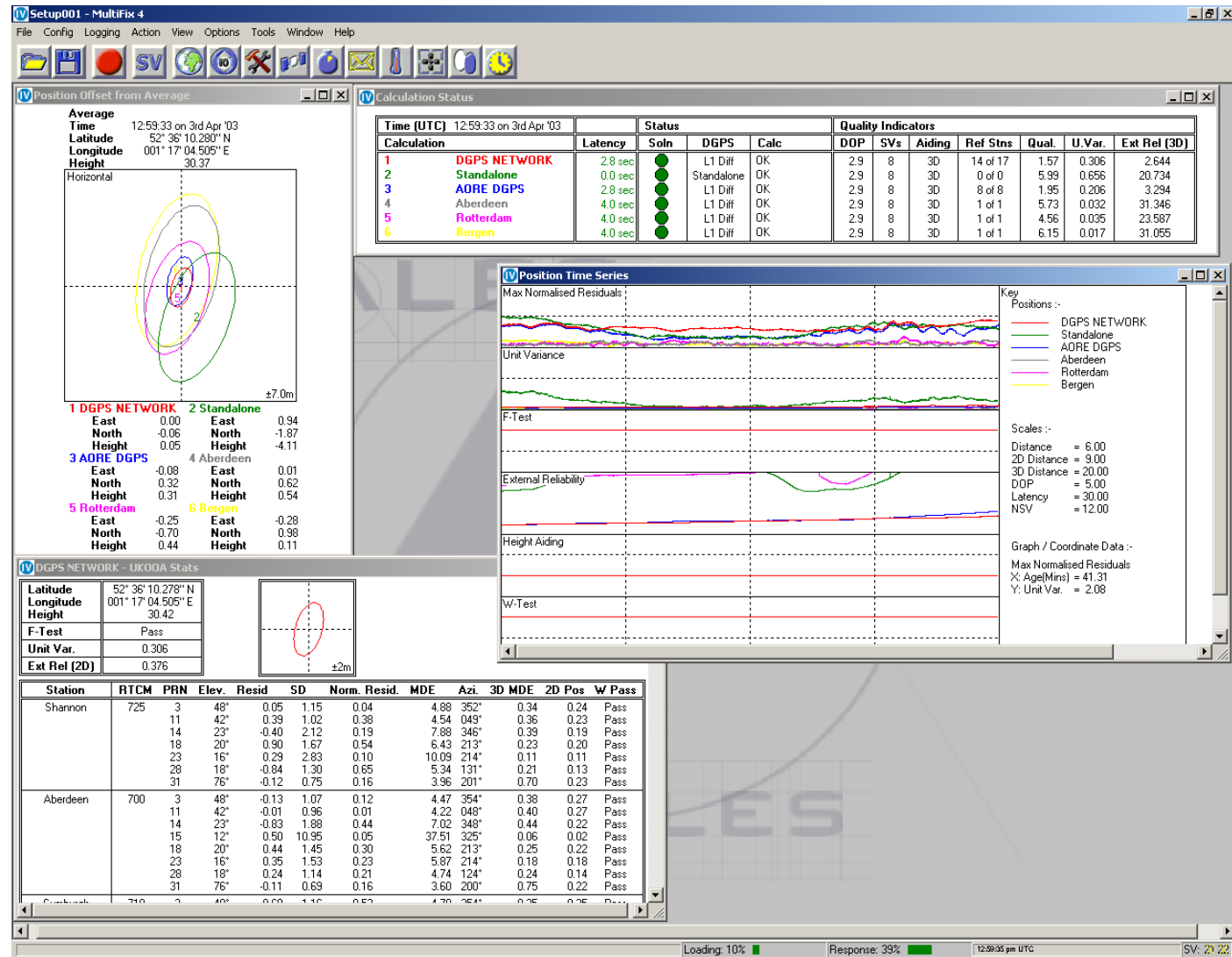

This MultiFix 4 display shows:

- Calculation Status
- XP Orbit Correction Data Table
- XP Orbit Correction Time Series Plot
- XP Solution position offsets and error ellipses
- Event Logger

**Setup001\_XP - MultiFix 4**

File Config Logging Action View Options Tools Window Help

---

**Calculation Status**

Time (UTC)	DP	Latency	Soln	DGPS	Calc	Quality Indicators						
Calculation						DOP	SVs	Aiding	Ref Stns	Qual.	U.Var.	Ext Rel (3D)
XP	XP Calculated	7.0 sec	●	L1/L2 Diff	OK - Converged	2.1	9	3D	N/A	0.34	0.038	0.128
Backup 1	DGPS NETWORK	3.8 sec	●	L1 Diff	OK	1.6	9	3D	10 of 10	1.33	0.269	2.000
Backup 2	Standalone	0.0 sec	●	Standalone	OK	1.6	9	3D	0 of 0	3.52	0.383	6.185
2	DGPS NETWORK	3.8 sec	●	L1 Diff	OK	1.6	9	3D	10 of 10	1.33	0.269	2.000
3	Standalone	0.0 sec	●	Standalone	OK	1.6	9	3D	0 of 0	3.52	0.383	6.185
4	AORE DGPS	5.0 sec	●	L1 Diff	OK	1.6	9	3D	8 of 8	1.38	0.145	1.952

---

**Orbit Correction Data**

Current Source	Latency	Station ID	Last Update
0	6.579	811	12:36:47

PRN	IODE	Age	dX	dY	dZ	dX dot	dY dot	dZ dot	Clk
1	93.0	021	0.156	-0.922	-1.117	0.00000	-0.00037	0.00000	
2	231.0	020	0.711	-2.102	-0.430	0.00000	0.00000	0.00000	
3	180.0	019	0.867	-2.070	0.719	0.00000	0.00000	0.00000	
4	176.1	018	-2.453	2.602	-0.898	0.00000	-0.00012	-0.00049	
5	190.0	017	2.336	2.563	0.633	0.00000	0.00000	0.00000	
6	67.0	016	-2.219	-2.852	1.336	-0.00061	-0.00024	0.00024	
7	164.1	015	-1.438	0.625	-2.273	-0.00037	-0.00012	0.00012	
8	234.1	014	-1.328	-1.008	-1.117	0.00000	0.00000	0.00000	
9	200.0	013	0.766	-1.438	1.117	0.00000	0.00000	0.00000	

---

**Recent Events**

Date/Time	Connection	Parameters	Description
03/04/2003 12:16:26.0	MultiFix 4		Configuration Change
03/04/2003 10:53:45.0	XP Calculation		Transition Completed
03/04/2003 10:52:39.0	XP Calculation		Calculation Changeover
03/04/2003 10:52:37.0	XP Calculation		Calculation Changeover
03/04/2003 10:52:30.0	XP Calculation		Calculation Changeover
03/04/2003 10:35:44.0	XP Calculation		Transition Completed
03/04/2003 10:35:25.5	RTCM station Ankara : Id 830		Input data OK
03/04/2003 10:35:25.5	RTCM station Cadiz : Id 810		Input data OK
03/04/2003 10:35:25.5	RTCM station Rome : Id 800		Input data OK
03/04/2003 10:35:25.5	RTCM station Bergen : Id 780		Input data OK
03/04/2003 10:35:25.5	RTCM station Bronnoysund : Id 770		Input data OK
03/04/2003 10:35:25.5	RTCM station Scillies : Id 760		Input data OK
03/04/2003 10:35:25.5	RTCM station Flamborough : Id 750		Input data OK
03/04/2003 10:35:25.5	RTCM station Rotterdam : Id 740		Input data OK
03/04/2003 10:35:25.5	RTCM station Sumburgh : Id 710		Input data OK
03/04/2003 10:35:25.5	RTCM station Aberdeen : Id 700		Input data OK
03/04/2003 10:35:25.5	RTCM station Shannon : Id 725		Input data OK
03/04/2003 11:36:25.0	MultiFix 4		Application Started
03/04/2003 11:36:25.0	MultiFix 4		Configuration Change
03/04/2003 11:36:25.0	MultiFix 4		Configuration Change

---

**XP Component Position Offset from Average**

Average Time: 12:36:40 on 3rd Apr '03  
 Latitude: 52° 36' 10.259" N  
 Longitude: 001° 17' 04.496" E  
 Height: 30.51

	1 XP Calculated	2 DGPS NETWORK	3 Standalone
East	-0.09	-0.04	0.76
North	-0.04	0.08	-0.42
Height	0.18	-1.26	-5.65

---

**Orbit Correction Plot**

Time Series - Calculated Position and Clock Offsets SV01

Time Series - Calculated Position and Clock Offsets SV05

Key: X (red), Y (green), Z (blue), Time (black)

Grid: 1-32